

Bus description

## PSD4xx positioning system – IO-Link

 **IO-Link**



halstrup-walcher GmbH  
Stegener Straße 10  
79199 Kirchzarten  
Germany

Tel. +49 7661 39 63-0  
[info@halstrup-walcher.com](mailto:info@halstrup-walcher.com)  
[www.halstrup-walcher.com](http://www.halstrup-walcher.com)

© 2025

The manufacturer owns the copyright to this instruction manual. It contains technical data, instructions and drawings detailing the device's features and how to use them. It must not be copied either wholly or in part or made available to third parties.

The instruction manual is part of the product. Please read this manual carefully, follow our instructions, and pay special attention to the safety information provided. This instruction manual should be available at all times. Please contact the manufacturer if you do not understand any part of the instructions.

The manufacturer reserves the right to continue developing this instrument model without documenting such development in each individual case. The manufacturer will be happy to determine whether this manual is up-to-date.

## Table of contents

<b>1. General</b> .....	<b>4</b>
1.1. Explanation of symbols .....	<b>4</b>
<b>2. Start-up</b> .....	<b>5</b>
2.1. Mounting and pin assignment .....	<b>7</b>
2.2. Grounding the drive.....	<b>7</b>
<b>3. Description of IO-Link</b> .....	<b>8</b>
3.1. Status LEDs.....	<b>8</b>
3.2. Table of entries implemented from object dictionary .....	<b>9</b>
3.3. Table of min-, / max- and default values .....	<b>26</b>
3.4. Definition of process data .....	<b>29</b>
3.5. Detailed description of bits in the status byte .....	<b>30</b>
3.6. Detailed description of control bits .....	<b>34</b>
<b>4. Functions</b> .....	<b>36</b>
4.1. Starting a positioning run .....	<b>36</b>
4.2. Types of positioning .....	<b>37</b>
4.2.1. Positioning run <i>with</i> loop .....	<b>37</b>
4.2.2. Positioning run <i>without</i> loop .....	<b>38</b>
4.2.3. Manual run.....	<b>38</b>
4.3. Velocity, acceleration and deceleration.....	<b>39</b>
4.4. Maximum start-up and operating current.....	<b>39</b>
4.5. Behaviour in case of blocking .....	<b>40</b>
4.6. Behaviour if the drive is turned manually (readjustment function) .....	<b>40</b>
4.7. Calculate the absolute physical position .....	<b>41</b>
4.8. Use of the "Upper mapping end" parameter.....	<b>44</b>
4.9. Set the spindle pitch .....	<b>52</b>
4.10. Modulo function.....	<b>53</b>
4.11. Changeover of parameter set.....	<b>56</b>
4.12. Aborted run when the master fails .....	<b>57</b>
4.13. Reference runs .....	<b>58</b>
4.14. Saving parameters .....	<b>58</b>
4.15. Run drive in reverse .....	<b>59</b>
<b>5. Technical data</b> .....	<b>60</b>
<b>6. Notes</b> .....	<b>61</b>

# 1. General

This description is to be used for the commissioning and integration of the drive into a field bus system.

Technical data for the electrical connections of your drive can be found in the electrical connector and pin assignment description on the website:



[www.halstrup-walcher.de/technicaldocu](http://www.halstrup-walcher.de/technicaldocu)

Please search for “PSD” and select your type, click on “Instruction manuals” and download the “connector and pin assignment” offered for your bus system.

## 1.1. Explanation of symbols

The device has been designed and tested to ensure its safety. However, it may still be dangerous if used inappropriately. Precautions must be taken to prevent the device being used incorrectly by mistake.

The following warnings are used in this instruction manual:

 <b>DANGER!</b>	<b>DANGER!</b> Indicates a situation of imminent danger, which will lead to a fatality or serious injuries if not prevented.
 <b>WARNING!</b>	<b>WARNING!</b> Indicates a potentially dangerous situation, which may lead to a fatality or serious injuries if not prevented.
 <b>CAUTION!</b>	<b>CAUTION!</b> Indicates a potentially dangerous situation, which may lead to minor/slight injuries if not prevented.
<b>NOTICE</b>	<b>NOTICE</b> Indicates a potentially harmful situation, which may lead to material damage if not prevented.

## 2. Start-up



### WARNING!

Risk of injury if used inappropriately.  
The device must be installed by trained technical personnel.



### WARNING!

Risk of burns due to hot drive.  
The drive can become very hot during operation.  
Allow the drive to cool before touching it.



### WARNING!

Risk of crushing due to rotary movement.  
Do not reach into the working area of the drive when it is still turning.  
The user/operator must ensure appropriate protective measures are taken.



### WARNING!

Incorrect assembly can lead to the destruction of the drive.



### WARNING!

Check that the supply lines are not pinched or crushed.  
Lay the supply lines according to the general and specific local assembly regulations.  
If the supply lines have not been delivered together with the device, please select suitable cables for the application.  
Do not operate the direct drive if the supply lines are noticeably damaged.



### WARNING!

Risk of injury. High contact voltages can occur in the case of malfunctions.  
This can be prevented by grounding.

 **CAUTION!**

The drive must be protected against excessive heating.  
The user/operator must ensure appropriate protective measures are taken.

 **CAUTION!**

Never apply force to the housing of the drive, e.g. for supporting weight.

## 2.1. Mounting and pin assignment

To turn on the PSD4xx, install the drive in the correct position according to the instructions in the installation manual.

For technical data on the electrical connections of your drive, please refer to the connection and plug description on the website.

You can find information about installing and the connection and pin assignment of the drive at the following link: [www.halstrup-walcher.de/technicaldocu](http://www.halstrup-walcher.de/technicaldocu)

Please search for "PSD" and select your type, click on "Instruction manuals" and download the "connector and pin assignment" offered for your bus system.

## 2.2. Grounding the drive

The device must be grounded before connecting it to the power supply cable. The grounding cable must be connected to the grounding screw (see illustration) on the device and connected to ground potential (e.g. machine base).

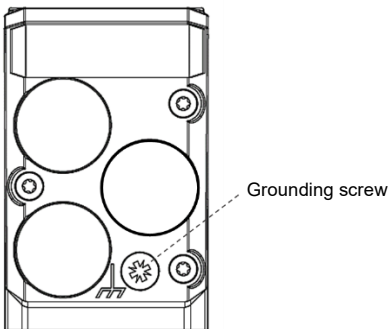

### NOTICE

The positioning system should be connected to the machine base using the shortest possible cable. The minimum wire cross-section of the grounding cable is 1.5 mm<sup>2</sup>.

Once the device has been grounded, it can be connected to the power supply and the communication interface. The drive is now ready for operation.

### 3. Description of IO-Link

#### NOTICE

For the IO-Link interface, the protocol used is SDCI according to IEC 61131-9 version 1.1.2.

#### 3.1. Status LEDs

The following LEDs are located under the sealing plug:

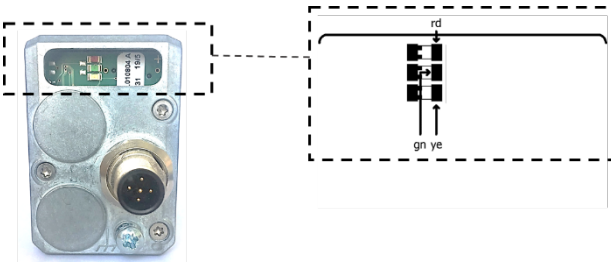

#### Green LED (gn) = RUN LED in accordance with IO-Link

Off	IO-Link communication not available
90% on, 10% off	IO-Link communication available

#### Yellow LED (ye) = Display motor voltage

Off	Motor voltage too low or too high
On	Motor voltage OK
Flashing at 0.5 Hz	Motor voltage OK and drive in the delivery state (concerning the values of all parameters and the position of the axis)



### 3.2. Table of entries implemented from object dictionary

#### NOTICE

Reserved bits or ISDUs must be described with 0.

Designation	ISDU no.	Function	Range of values	Back up?	Delivery state	R/W
<b>IO-Link standard variables</b>						
Direct parameter 1	0	Sub 1: Master command	8 bit			W
		Sub 2: Master cycle time	8 bit			R/W
		Sub 3: Minimum cycle time	8 bit		68	R
		Sub 4: Telegram capability	8 bit		43	R
		Sub 5: IO-Link version ID	8 bit		17	R
		Sub 6: Process data length input	8 bit		135	R
		Sub 7: Process data length output	8 bit		16	R
		Sub 8: Manufacturer ID 1	8 bit		2	R
		Sub 9: Manufacturer ID 2	8 bit		216	R
		Sub 10: Device ID 1	8 bit			R
		Sub 11: Device ID 2	8 bit			R
		Sub 12: Device ID 3	8 bit			R
		Sub 13: Reserved	8 bit		0	R
		Sub 14: Reserved	8 bit		0	R
		Sub 15: Reserved	8 bit		0	R
		Sub 16: Standard command	8 bit			W
Standard command	2	To trigger specific commands:	8 bit			W
		<b>Value    Meaning</b>				
		128      Reset the device				
		130      Restore delivery state				
		161      Save parameters in EEPROM				

Designation	ISDU no.	Function	Range of values	Back up?	Delivery state	R/W
<b>IO-Link standard variables</b>						
Device access locks	12	Bit 0: Parameter (write) access lock Bit 1: Data storage lock Bit 2: Local parameterisation lock Bit 3: Local user interface lock Bit 4..15: Reserved	16 bit	Yes	0	R/W
Name of manufacturer	16	"halstrup-walcher GmbH"	String			R
Manufacturer text	17	"www.hwg.eu"	String			R
Product name	18	Dependent on device type, e.g. "PSD422-8H"	String			R
Product ID	19	"PSD"	String			R
Product text	20	"Positioning System"	String			R
Serial number	21	As a 5-character string, e.g. "00042"	String			R
Hardware version	22	e.g. "V1.0"	String		"V1.0"	R
Firmware version	23	e.g. "V1.0"	String		"V1.0"	R
Application-specific marking	24	Any text (max. 16 characters)	String		""	R/W

Designation	ISDU no.	Function	Range of values	Back up?	Delivery state	R/W
<b>Status requests</b>						
Status byte	64	Bit 0: Target position reached Bit 1: Reserved Bit 2: Toggle bit Bit 3: Reserved Bit 4: Motor power present Bit 5: Positioning run aborted Bit 6: Drive is running Bit 7: Temperature exceeded Bit 8: Movement opposite loop direction Bit 9: Error Bit 10: Positioning error (block) Bit 11: Manual displacement Bit 12: Incorrect target value Bit 13: Motor power was missing Bit 14: Positive range limit Bit 15: Negative range limit	0..FFFFh 16 bit			R
Actual rpm	66	Current speed in rpm	± 15 bit			R
Write actual position	67	If this parameter is set to 0 and the subsequent write command is the actual position (ISDU 68), the writing of the actual position is suppressed.	0...1 8 bit	No	0	R/W

Designation	ISDU no.	Function	Range of values	Back up?	Delivery state	R/W
<b>Status requests</b>						
Actual position	68	Current actual position, value in 1/100 mm  (For default values of numerator, ISDU 116 and denominator, ISDU 117 and spindle pitch 4 mm)  Writing to this index number causes the current position to be "referenced" to the transferred value.  Writing is only possible when stationary.	± 31 bit	No		R/W
Actual current	69	Actual current; in mA	16 bit			R
Max. actual current during last run	70	Max. actual current during last run, in mA	16 bit			R
U control	71	Current supply voltage to control unit, in 0.1 V	16 bit			R
U motor	72	Current supply voltage to motor, in 0.1 V	16 bit			R
Device temperature	73	Internal device temperature in °C (Accuracy: ± 5 K)	± 15 bit			R
Production date	76	Year and week of manufacture (given as an integer)	YYWW 16 bit			R
Serial number	77	Device serial number	0.. 65535 16 bit			R

Designation	ISDU no.	Function	Range of values	Back up?	Delivery state	R/W
<b>Status requests</b>						
Device type	78	The respective device type from the PSD series (the last 2 digits of the 5-digit numbers refer to the diameter of the output shaft, e.g. 42208 → 8 mm shaft):  40105, 40108, 40114, 40308, 40314, 41105, 41108, 41114, 41308, 41314, 42208, 42214, 42414, 42614, 42814, 43208, 43214, 43414, 43614, 43814, 48005, 48008, 48014, 48108, 48114, 49005, 49008, 49014, 49108, 49114	16 bit			R
Software version	79	Software version number	16 bit			R
Number of steps in second positioning	82	Number of steps that the drive moved in the second positioning. Thus it can be evaluated if there was a step loss.  (available from firmware V19)	32 bit			R
Raw position of absolute measurement unit	83	Raw value of actual position (4096 steps per motor rotation)  value range [-2016 ... 2016] motor shaft rotations  (available from firmware V19)	± 31 bit			R
Number of sectors in Modulo mode	84	Dependent of the scaling (numerator/denominator, see ISDU 116 and 117) and the modulo range (see ISDU 185 and 186).  If the modulo mode is active, the value should not exceed the value 10,000 (if necessary, modify the scaling or the modulo range).  (available from firmware V19)	16 bit			R

Designation	ISDU no.	Function	Range of values	Back up?	Delivery state	R/W
<b>Status requests</b>						
Available additional functions	85	The value indicates which additional functions are available. The individual bits indicate the availability of a certain additional function. If the bit is set, the corresponding additional function is available.  Bit 0: Modulo mode Bit 1: Changeover of parameter set Bit 2: Target speed in process data  (available from firmware V19)	16 bit			R

Designation	ISDU no.	Function	Range of values	Back up?	Delivery state	R/W
<b>Run commands</b>						
Write command byte	109	If this parameter is set to 0 and the subsequent write command is the command byte (ISDU 110), the writing of the command byte is suppressed.	0...1 8 bit	No	0	R/W
Command byte	110	Bit 0: Manual run to larger values Bit 1: Manual run to smaller values Bit 2: Transfer target value (When transferring the target value with the aid of process data, the target value is accepted only if this bit is set.) Bit 4: Release, the axis is only driven when the bit is set Bit 6: Run without loop Bit 8-9: Changeover of parameter set (available from firmware V19 for the variants with the feature "software modules" = "S" or "Z") Bit 13: Toggle bit Bit 14: Error Acknowledge (available from firmware V19) All other bits are reserved and must be set to 0	16 bit	No	0	R/W
Write target value	111	If this parameter is set to 0 and the subsequent write command affects the target position (ISDU 112), the writing of the target value is suppressed.	0...1 8 bit	No	0	R/W

Designation	ISDU no.	Function	Range of values	Back up?	Delivery state	R/W
<b>Run commands</b>						
Target value	112	Target position Value in 1/100 mm (for default values of numerator, ISDU 116 and denominator, ISDU 117 and spindle pitch 4 mm)	± 31 bit	No	0	R/W



Designation	ISDU no.	Function	Range of values	Back up?	Delivery state	R/W
<b>“Positioning values” parameter group</b>						
Direction of rotation	115	0: clockwise (when looking at the output shaft)  1: counter clockwise  Writing is only possible when standing still.	0 or 1 8 bit	Yes	0	R/W
Actual value assessment numerator	116	These values allow you to apply any resolution to the drive that you wish.	1... 10000 16 bit	Yes	400	R/W
Actual value assessment, denominator	117	For a numerator factor of 400, the spindle pitch/resolution is stated in the denominator factor  e.g.: spindle pitch 1.5 mm with resolution 1/100 mm: numerator = 400, denominator = 150  Writing is only possible when standing still.	1... 10000 16 bit	Yes	400	R/W
Write referencing value	118	If this parameter is set to 0 and the subsequent write command affects the referencing value (ISDU 119), the writing of the referencing value is suppressed.	0...1 8 bit	No	0	R/W
Referencing value	119	Correction factor for the target, actual and limit switch values  Writing is only possible when standing still.	± 31 bit	Yes	0	R/W

Designation	ISDU no.	Function	Range of values	Back up?	Delivery state	R/W
<b>"Positioning values" parameter group</b>						
Upper mapping end	120	Definition of the positioning range relative to the absolute value encoder  Permissible values for PSD401/411/422/432/480/490: (current position + 3 rotations) ... (current position + 4,029 rotations)  For models with an auxiliary gearbox, the range of values is reduced in accordance with the gear ratio (see chapter 3.3.).  Ineffective in modulo mode.  Writing is only possible when standing still.	± 31 bit	Yes	See chap. 3.3	R/W
Upper limit	121	Maximum permitted target position  Permissible values for PSD401/411/422/432/480/490:  Upper mapping end - 1,200 .. 1,611,600 * denominator/numerator  For models with an auxiliary gearbox, the range of values is reduced in accordance with the gear ratio (see chapter 3.3.).  Ineffective in modulo mode.	± 31 bit	Yes	See chap.3.3	R/W

Designation	ISDU no.	Function	Range of values	Back up?	Delivery state	R/W
<b>“Positioning values” parameter group</b>						
Lower limit	122	<p>Minimum permissible target position</p> <p>Permissible values for PSD401/411/422/432/480/490:</p> <p>Upper mapping end - 1,200 .. 1,611,600 * denominator/numerator</p> <p>For models with an auxiliary gearbox, the range of values is reduced in accordance with the gear ratio (see chapter 3.3.).</p> <p>Ineffective in modulo mode.</p>	± 31 bit	Yes	See chap.3.3	R/W
Positioning window	123 *)	<p>Permissible difference between target and actual values for the “position reached” bit</p> <p>The maximum setting value changes according to the same factor as the resolution.</p> <p>Value range for standard settings of numerator (ISDU 116) and denominator (ISDU 117): 1 .. 100 steps</p>	0.0025... 0.25 rotations 16 bit	Yes	2	R/W

\*) For the variants with the option “changeover of parameter set” (i.e. variants with the feature “software modules” = “S” or “Z”) this ISDU has 4 sub-indices (see chapter “changeover of parameter set”).

Designation	ISDU no.	Function	Range of values	Back up?	Delivery state	R/W
<b>“Positioning values” parameter group</b>						
Loop length	124	<p>Minimum number of increments, in which the drive runs to a target in a specified direction.</p> <p>Value in increments (0 → no loop)</p> <p>The sign determines the direction of the loop (positive → loop run to larger values; negative → loop run to smaller values)</p> <p>Value range for standard settings of numerator (ISDU 116) and denominator (ISDU 117):</p> <p>-4,000 ... -10 steps and 10 ... 4,000 steps and 0</p> <p>Ineffective in modulo mode.</p> <p>(Exception: The sign of the loop length also defines the direction from which readjustment takes place in modulo mode.)</p> <p>Writing is only possible when standing still.</p>	<p>0.025 ... 10 rotations</p> <p>or</p> <p>-0.025... -10 rotations</p> <p>or</p> <p>0</p> <p>± 31 bit</p>	Yes	250	R/W
Read-justment	126	<p>0 = without readjustment</p> <p>1 = with readjustment</p>	8 bit		0	R/W

Designation	ISDU no.	Function	Range of values	Back up?	Delivery state	R/W
<b>“Speed” parameter group</b>						
Target speed (rpm) for positioning runs	137 *)	Maximum target speed to be used for positioning runs Value in rpm	See chap. 3.3 16 bit	Yes	See chap. 3.3	R/W
Target speed (rpm) for manual runs	138 *)	Maximum target speed to be used for manual runs Value in rpm	See chap. 3.3 16 bit	Yes	See chap. 3.3	R/W
Acceleration 1	139 *)	Value in rpm per second	See chap. 3.3 16 bit	Yes	See chap. 3.3	R/W
Deceleration 1	141 *)	Value in rpm per second	See chap. 3.3 16 bit	Yes	See chap. 3.3	R/W
Speed limit (rpm) for run abort	143 *)	Value in % of the target rpm	30...90 16 bit	Yes	30	R/W

\*) For the variants with the option “changeover of parameter set” (i.e. variants with the feature “software modules” = “S” or “Z”) this ISDU has 4 sub-indices (see chapter “changeover of parameter set”).

Designation	ISDU no.	Function	Range of values	Back up?	Delivery state	R/W
<b>“Torque” parameter group</b>						
Max. start-up current	147 *)	in mA	See chap. 3.3 16 bit	Yes	See chap. 3.3	R/W
Maximum operating current	148 *)	in mA	See chap. 3.3 16 bit	Yes	See chap. 3.3	R/W
Max. holding current at end of run	149 *)	in mA	See chap. 3.3 16 bit	Yes	See chap. 3.3	R/W
Maximum holding current	150 *)	in mA	See chap. 3.3 16 bit	Yes	See chap. 3.3	R/W

\*) For the variants with the option “changeover of parameter set” (i.e. variants with the feature “software modules” = “S” or “Z”) this ISDU has 4 sub-indices (see chapter “changeover of parameter set”).

Designation	ISDU no.	Function	Range of values	Back up?	Delivery state	R/W
<b>“Time” parameter group</b>						
Time elapsed until speed falls below rpm limit for aborting run	154 )	Value in ms	50 ... 500 16 bit	Yes	200	R/W
Time period for start-up current	155 )	Value in ms	10 ... 1000 16 bit	Yes	200	R/W
Duration of max. holding current at end of run	157 )	Value in ms	0 ... 1000 16 bit	Yes	200	R/W
UMot filter	161	Average time for UMot voltage measurement (in steps of 1 ms)	100 ... 1000 16 bit	Yes	100	R/W
Communication timeout	162	Value in ms  If the value is 0, the communication timeout is deactivated. A value > 0 defines the time within which the master must send a new message to maintain the connection.  A timeout results in an abortion of the run.	0 ... 10,000 16 bit	Yes	0	R/W

\*) For the variants with the option “changeover of parameter set” (i.e. variants with the feature “software modules“ = “S” or “Z”) this ISDU has 4 sub-indices (see chapter “changeover of parameter set”).

Designation	ISDU no.	Function	Range of values	Back up?	Delivery state	R/W
<b>“Other” parameter group</b>						
E-Ident value 1	167	applicable for the unique electronic device identification The values of both ISDUs are not resetted by the conventional commands to recall the delivery state. Only setting ISDU 194 to “-4” will set the values of these ISDUs to 0.  (available from firmware V28)	32 bit	ja	0	R/W
E-Ident value 2	168		32 bit	ja	0	R/W
Free register	169	Freely-usable register	± 31 bit	Yes	0	R/W
UMot limit	179	Voltage limit for bit “Motor power present” given in increments of 0.1 V	180 ...240 16 bit	Yes	185	R/W
Temperature limit	180	Upper temperature limit in °C	10 ... 80 16 bit	Yes	80	R/W
Modulo mode	184 **)	0 → Modulo function inactive 1 → Run to larger values 2 → Run to smaller values 3 → Shortest way 4 → Run to larger values with blocking zone 5 → Run to smaller values with blocking zone	0 ... 5 8 bit	Yes	0	R/W
Upper modulo position	185 **)	Highest position of the modulo range When this position is reached, the actual position jumps to the value [lower modulo position]. (value in steps)	± 31 bit	Yes	3600	R/W
Lower modulo position	186 **)	Lowest position of the modulo range If the actual position falls below this value, it jumps to the value [Upper modulo position - 1]. (value in steps)	± 31 bit	Yes	0	R/W

\*\* ) The ISDUs 184-186 are available from firmware V19. For the variants with the option “Modulo function” (i.e. variants with the feature “Software modules” = “M” or “Z”), the modulo function is configured with these ISDUs. For the variants without modulo function (i.e. variants with the feature “software modules” = “1”, “S” or “P”) only the default value can be written, other values are rejected.



Designation	ISDU no.	Function	Range of values	Back up?	Delivery state	R/W
<b>“Other” parameter group (continuation)</b>						
Delivery state	194	<p><b>Writing a “-5”:</b> Resets the drive (corresponds to switching the control voltage off and on again)</p> <p><b>Writing a “-4”:</b> Resets all parameters to the delivery states (including the electronic device identification, see ISDU 167 + 168) without saving the parameters in EEPROM, without a start-up reference loop and without positioning in the middle of the measurement range.</p> <p><b>Writing a “-3”:</b> Resets all parameters to the delivery states without saving the parameters in EEPROM, without a start-up reference loop and without positioning in the middle of the measurement range (electronic device identification remains unaffected, see ISDU 167 + 168).</p> <p><b>Writing a “-1”:</b> Resets all parameters to the delivery states without saving the parameters in EEPROM. The drive then performs a start-up reference loop and positions itself in the middle of the measurement range (electronic device identification remains unaffected, see ISDU 167 + 168).</p> <p><b>Writing a “0”:</b> No action</p> <p><b>Writing a “1”:</b> Saves the parameter in EEPROM.</p> <p><b>Reading after booting:</b> 0 → Memory cont. correct ≠ 0 → Memory cont. incorrect</p> <p><b>Reading after saving:</b> 0 → Saving completed ≠ 0 → Saving is not yet complete or terminated with errors (saving can take up to 2000 ms)</p>	<p>-5...1 (during writing)</p> <p>0...2 (during reading)</p> <p>± 15 bit</p>	No	0	R/W

### 3.3. Table of min-, / max- and default values

#### NOTICE

The operating current setting is optimised for the nominal rated speed of the respective device model. The more the set speed deviates from the nominal rated speed (rpm), the greater the current consumption deviates from the set current value

#### NOTICE

Setting the value for the holding current to 0 results in a current consumption by the motor circuit of approx. 50 mA.

Device type		PSD 401/411 - 5V	PSD 401/411 - 8H/14H	PSD 403/413 - 8H/14H	PSD 422/432 - 8V	PSD 422/432 - 8H/14H
Name	ISDU no.	Range of values Delivery state				
Upper mapping end	120	Min. value = current position + 1200 * denominator/numerator Max. value = current position + a * denominator/numerator Default value = 806,400   806,400   198,498   806,400   806,400				
Upper limit	121	Min. value = upper mapping end - a * denominator/numerator Max. value = upper mapping end - 1200 * denominator/numerator Default value = 805,200   805,200   197,298   805,200   805,200				
Lower limit	122	Min. value = upper mapping end - a * denominator/numerator Max. value = upper mapping end - 1200 * denominator/numerator Default value = -805,200   -805,200   -197,298   -805,200   -805,200				
Variable "a" for formula (see above)	120- 122	1,611,600	1,611,600	395,797	1,611,600	1,611,600
Target rpm Positioning	137	1...800 200	1...500 200	1...250 50	1...1000 200	1...500 200
Target rpm, Manual run	138	1...800 70	1...500 70	1...250 17	1...1000 70	1...500 70

Device type		PSD 401/411 - 5V	PSD 401/411 - 8H/14H	PSD 403/413 - 8H/14H	PSD 422/432 - 8V	PSD 422/432 - 8H/14H
Name	ISDU no.	Range of values Delivery state				
Acceleration	139	1...5000 1000	1...5000 1000	1...1250 250	1...5000 500	1...5000 500
Deceleration	141	1...5000 2000	1...5000 2000	1...1250 500	1...5000 2000	1...5000 2000
Max. start-up current	147	5...2000 1000	5...2000 1000	5...2000 1000	5...4000 2000	5...4000 2000
Max. operating current	148	5...2000 750	5...2000 750	5...2000 750	5...4000 1500	5...4000 1500
Max. holding current at end of run	149	0...600 60	0...600 60	0...600 60	0...800 80	0...800 80
Maximum holding current	150	0...300 30	0...300 30	0...300 30	0...400 40	0...400 40

Device type		PSD 424/434 - 14H	PSD 426/436 - 14H	PSD 428/438 - 14H	PSD 480/490 - 5V	PSD 480/490 - 8H/14H	PSD 481/491 - 8H/14H
Name	ISDU no.	Range of values Delivery state					
Upper mapping end	120	Min. value = current position + 1200 * denominator/numerator Max. value = current position + a * denominator/numerator Default value = 388,800   256,000   196,683   806.400   806.400   198.498					
Upper limit	121	Min. value = upper mapping end - a * denominator/numerator Max. value = upper mapping end - 1200 * denominator/numerator Default value = 387,600   254,800   195,483   805.200   805.200   197.298					
Lower limit	122	Min. value = upper mapping end - a * denominator/numerator Max. value = upper mapping end - 1200 * denominator/numerator Default value = -387,600   -254,800   -195,483   -805.200   -805.200   -197.298					
Variable "a" for formula (see above)	120- 122	776,400	510,800	392,166	1.611.600	1.611.600	395.797
Target rpm Positioning	137	1...482 100	1...317 63	1...250 50	1...800 200	1...500 200	1...250 50
Target rpm, Manual run	138	1...482 34	1...317 22	1...250 17	1...800 70	1...500 70	1...250 17
Acceleration	139	1...2411 240	1...1587 150	1...1250 125	1...5000 1000	1...5000 1000	1...1250 250
Deceleration	141	1...2411 960	1...1587 635	1...1250 500	1...5000 2000	1...5000 2000	1...1250 500
Max. start-up current	147	5...4000 2000	5...4000 2000	5...4000 2000	5...1900 950	5...1900 950	5...1900 950
Max. operating current	148	5...4000 1500	5...4000 1500	5...4000 1500	5...1900 712	5...1900 712	5...1900 712
Max. holding current at end of run	149	0...800 80	0...800 80	0...800 80	0...500 50	0...500 50	0...500 50
Max. holding current	150	0...400 40	0...400 40	0...400 40	0...250 25	0...250 25	0...250 25

### 3.4. Definition of process data

1) Process **output** data: 6 or 8 byte (from the point of view of the IO-Link master)

Assignment for variants **without** the option "target speed in process data"  
(i.e. variants with the feature "software modules" = "1", "M" or "S")

Bit	Byte	Meaning	Corresponding IO-Link parameters
0..15 (16 Bit)	0, 1	Command byte	110
16..47 (32 Bit)	2..5	Target position	112

Assignment for variants **with** the option "target speed in process data"  
(i.e. variants with the feature "software modules" = "P" or "Z")

Bit	Byte	Meaning	Corresponding IO-Link parameters
0..15 (16 Bit)	0, 1	Target speed	137 (Positioning run) or 138 (Manual run)
16..31 (16 Bit)	2, 3	Command byte	110
32..63 (32 Bit)	4..7	Target position	112

#### NOTICE

For reasons of compatibility, the *Target Speed* in the process data has been placed before the *Command Byte* and *Target Position*.

This makes it possible for some Control Units to continue to use function blocks that have already been developed and, if necessary, to add the setpoint speed as bytes 6..7 **at the end of the block** consisting of the *Command Byte* and *Target Position*.

2) Process **input** data: 8 byte (from the point of view of the IO-Link master)

Bit	Byte	Meaning	Corresponding IO-Link parameters
0..15 (16 Bit)	0, 1	Status byte	64, see chap 3.5.
16..31 (16 Bit)	2, 3	Actual rpm	66
32..63 (32 Bit)	4..7	Actual position	68

#### NOTICE

The assignments cannot be changed.

Some IO-Link bus masters process the data in the opposite byte order, this applies to both the output and the input data. In practice, the order of the data can be easily determined by cyclically switching the motor voltage on and off when the bus connection is established and the drive is at standstill. Bit 4 of the status word ("Motor power present") then changes level cyclically accordingly, thus byte 0 of the status word can be identified.

### 3.5. Detailed description of bits in the status byte

#### Bit 0 Target position reached

*This bit is set:*

- when a transferred target position has been reached successfully
- after running a start-up reference loop, when the actual value corresponds to the previously transferred target value
- after manual displacement while at standstill, if readjustment is activated and the absolute value of the difference of actual and target value is smaller or equal to the positioning window again.

*This bit is reset:*

- after transferring a target position if the release bit is set and when the difference from the actual value is larger than the positioning window (ISDU 123)
- by a manual run
- if an invalid target value has been transferred
- as a result of manual rotation when not in operation

#### Bit 1 Reserved

#### Bit 2 Toggle bit

*This bit is set:*

- if bit 13 of the command byte is set

*This bit is reset:*

- if bit 13 of the command byte is reset

#### Bit 3 Reserved

#### Bit 4 Motor power present

*This bit is set:*

- if the supply voltage for the motor is above the U<sub>Mot</sub> limit (ISDU 179) and below 30 V

*This bit is reset:*

- if the supply voltage for the motor is below the U<sub>Mot</sub> limit or above 30 V

#### Bit 5 Positioning run aborted

*This bit is set:*

- if a positioning run is aborted because the release has been withdrawn in the command byte

*This bit is reset:*

- when a new run command is transmitted
- with a 0 → 1 edge of the bit "Error Acknowledge" (available from FW V19)

## Description of IO-Link

### **Bit 6 Drive is running**

*This bit is set:*

- when the drive is rotating

*This bit is reset:*

- when the drive is at a standstill

### **Bit 7 Temperature exceeded**

*This bit is set:*

- when the internal device temperature rises above the limit value from ISDU 180

*This bit is reset:*

- when the internal device temperature falls below the limit value by 5 °C

### **Bit 8 Movement opposite loop direction**

*This bit is set:*

- after power up or a reset command  
(any backlash in the driven spindle is not yet eliminated)
- during manual runs in the direction opposite that of the positioning run  
(a subsequent manual run in the direction of the positioning run will no longer delete this bit)
- during a positioning sequence in the direction opposite to that of the loop direction

*This bit is reset:*

- when a transferred target position has been reached successfully  
(in the direction of the loop)
- after the start-up reference loop

### **Bit 9 Error bit**

*This bit is set:*

- if an unrecoverable error in flash memory occurred
- when an internal problem is detected when calculating the position

**No more run commands may be transmitted when the error bit is set!**

*This bit is reset:*

- only by resetting the drive (reset command or switching off and on again)

**Bit 10 Positioning error (block)**

*This bit is set:*

- if a positioning run is aborted because the device is overloaded (obstructions, extreme difficulty running)

*This bit is reset:*

- by transmitting a new positioning command
- with a 0 → 1 edge of the bit "Error Acknowledge" (available from FW V19)
- after a start-up reference loop has been correctly executed

**Bit 11 Manual displacement**

*This bit is set:*

- if, while at a standstill, the drive is rotated externally by more than the value in the positioning window

*This bit is reset:*

- by transmitting a new positioning command
- with a 0 → 1 edge of the bit "Error Acknowledge" (available from FW V19)
- after a correctly-completed initial reference loop

**Bit 12 Incorrect target value**

*This bit is set:*

- if a transferred target value lies outside the range of the limit switches, caused e.g. by the current referencing value (ISDU 119)
- if a transferred target value lies within the range of the limit switches, but would leave the specified range during the required loop
- if a new target speed is transmitted in the process data for the variants with the option "target speed in process data" (i.e. variants with the feature "software modules" = "P" or "Z") and this is outside the permissible value range

*This bit is reset:*

- by transmitting a valid target value
- with a 0 → 1 edge of the bit "Error Acknowledge" (available from FW V19)

**Bit 13 Motor power was missing**

*This bit is set:*

- if the motor voltage is less than the UMot limit (ISDU 179) or above 30 V when initiating a positioning run or start-up reference loop
- if the motor voltage leaves the specified range during the run

*This bit is reset:*

- if the motor voltage is greater than the UMot limit and under 30 V when initiating a positioning run or start-up reference loop
- with a 0 → 1 edge of the bit "Error Acknowledge" (available from FW V19)



## Description of IO-Link

### **Bit 14/** Forward/reverse limit reached

#### **Bit 15**

*This bit is set:*

- if the limit value is reached during a manual run (not when reached during a positioning run)
- if a limit is modified such that the current position lies beyond it
- if, when at a standstill, the drive is moved to a position beyond the range defined by the limit switches by an external force

*This bit is reset:*

- when the actual position is again within the positioning range limits

**Exception:** after completing a manual run, the drive is at the range limit, still within the positioning window and new run command has not yet been issued).

### 3.6. Detailed description of control bits

**Bit 0**      **Manual run to larger values**

**Bit 1**      **Manual run to smaller values**

**Bit 2**      **Transfer target value**

If this bit is set, the target value sent in the same process data telegram is accepted as the new valid target value. A positioning run that starts simultaneously or later uses this target value as the new target position. If a positioning is to be started immediately together with the acceptance of the target value, bit 4 (“release”) must be set simultaneously in addition to bit 2.

If bit 2 is not set, the target value is not accepted; instead, by setting the release bit, a positioning run can be carried out to the target value last transferred and marked as valid.

**Bit 3**      **Reserved**

must be set to 0

**Bit 4**      **Release**

Run commands will only be executed if this bit is set. This bit must be set for positioning runs and manual runs. If this bit is reset during a run, the run will be aborted and status bit 5 (“Run aborted”) will be set.

**Bit 5**      **Reserved**

must be set to 0

**Bit 6**      **Run without loop**

If this bit is set during positioning runs, all target positions will be approached directly (independently of the current value in ISDU 124) without any loop.

**Bit 7**      **Reserved**

must be set to 0

**Bit 8-9**    **Changeover of parameter set:**

Selection of desired set (available from firmware V19 for variants with the feature “software modules” = “S” or “Z”)

- Bits 9..8 = 0x00 → parameter set 1
- Bits 9..8 = 0x01 → parameter set 2
- Bits 9..8 = 0x02 → parameter set 3
- Bits 9..8 = 0x03 → parameter set 4

**Bit 10-12**    **Reserved**

must be set to 0

## Description of IO-Link

### **Bit 13**      **Toggle bit**

Always when a command byte is received, the drive writes the value of this bit in status byte bit 2.

→ The control unit can recognize when new process data are processed by the drive.

### **Bit 14**      **Error Acknowledge:**

with a 0 → 1 edge of this bit, the error bits 5, 10, 11, 12 and 13 in the status byte are acknowledged (available from firmware V19).

### **Bit 15**      **Reserved**

must be set to 0

## 4. Functions

### 4.1. Starting a positioning run

To control the drive, it must first be switched to the IO-Link state "operate".

**The following sequence of steps is possible:**

- Transfer target value:  
Command byte = 0x14 and desired target value  
→ Drive begins run
- Aborting a run by withdrawing release:  
Command byte = 0x00

#### NOTICE

If a new target value needs to be set during an active positioning run, the drive must be stopped (reset the release bit). The new target value can be set when the drive is at a standstill.

#### NOTICE

If a manual run is required during an active positioning run, the drive must be stopped (reset the release bit). The manual run can be started when the drive is at a standstill.

**The following sequence of steps is also possible:**

Starting condition: release has not been set.

- Transfer target value:  
Command byte = 0x04 and desired target value
- Set release:  
Command byte = 0x10  
→ Drive begins run
- Aborting a run by withdrawing release:  
Command byte = 0x00

Positioning runs may include a "loop run", which causes the target to be approached from a defined direction. The direction and length of the loop run can be set to the desired value with ISDU 124 ("loop length") before the positioning run begins. ISDU 124 can also be used to deactivate the loop run.

## 4.2. Types of positioning

### 4.2.1. Positioning run *with loop*

The PSD4xx distinguishes between the following steps of a positioning sequence (Assumption: the target position is always approached through forward motion):

- 1) New position value is larger than the current value: position approached directly.

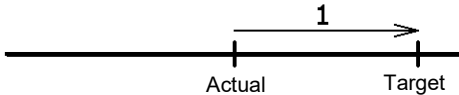

- 2) New position value is smaller than the current value: the drive reverses an additional 5/8 of one rotation (2a) and approaches the exact position after resuming forward motion (2b)

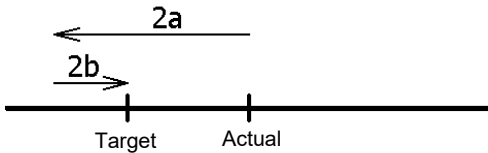

- 3) New position value after reverse run (no loop): the drive always approaches by moving forward (3b), if necessary, it will first reverse by 5/8 of a rotation (3a).

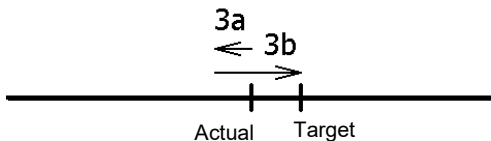

After reaching the target position, this position is compared with the internal absolute encoder position. If the deviation is more than 0.9° (at the motor shaft) a second positioning is automatically started and the drive will move to the target position again. After the positioning is terminated (first positioning and, if necessary, second positioning), the reached position is compared with the target position. If the reached position is outside the positioning window (ISDU 123), the status bit "Positioning error (block)" is set.

### NOTICE

It is not possible to perform a positioning run to the upper limit (ISDU 121) with a loop length < 0 because the drive would have to run past the upper limit in order to do so. The same applies to the lower limit (ISDU 122) with loop length > 0.

#### 4.2.2. Positioning run *without* loop

The “positioning without loop” mode is used primarily for moving the small distances involved in fine adjustments. In this case, each position is approached directly.

##### NOTICE

To perform a positioning run without a loop, in addition to setting the release (bit 4 in the command byte), you must also set bit 6 (“run without loop”) or ISDU 124 (“loop length”) must have the value 0.

##### NOTICE

In this mode any backlash that might be produced by the driven spindle is NOT eliminated. For models with an integrated auxiliary gearbox, in this case also the internal gear backlash does influence the positioning accuracy.

#### 4.2.3 Manual run

The drive can be operated manually (so-called “manual run”). This helps to simplify commissioning.

- Transfer manual run:  
Command byte = 0x11 and/or 0x12  
→ Drive begins run
  
- End manual run by withdrawing manual run command:  
transmit command byte = 0x10

*or*

- Removal of the release  
→ transmit command byte = 0x00

##### NOTICE

If a positioning run is required during an active manual run, the drive must be stopped (reset the release bit). The positioning can be started when the drive is at a standstill (command byte = 0x14 and required target value).

### 4.3. Velocity, acceleration and deceleration

Start-up reference loops and manual runs are performed at the maximum velocity from ISDU 138.

Positioning runs are performed at the maximum velocity from ISDU 137.

For the variants with the option "Target speed in process data" (i.e. variants with the feature "software modules" = "P" or "Z"), all runs are executed with the target speed sent in the process data, the values from ISDU 137 or ISDU 138 are then ignored.

There are two exceptions to this:

- 1) If the value 0 is sent as the target speed in the process data, the speed target values from ISDU 137 for position movements or ISDU 138 for manual movements will continue to be applied (for variants with changeover of parameter set, the values from the currently selected motion block; see chapter "changeover of parameter set").
- 2) If an impermissible speed target value is sent (e.g. values > 317 for PSD426/436), the run command is rejected and bit 12 in the status word ("Incorrect target value") is set. In this case, a currently active run is aborted.

For all runs, the maximum acceleration from ISDU 139 and the maximum deceleration from ISDU 141 apply.

#### NOTICE

If during a run the release bit in the command byte is cleared or the target position is approached, the deceleration is carried out with the parameter "deceleration" (ISDU 141). If the speed is increased or decreased during a run, the parameter "acceleration" is used (ISDU 139).

### 4.4. Maximum start-up and operating current

The maximum start-up current can be set via ISDU 147, the maximum operating current can be set via ISDU 148.

The start-up current is active after each run begins for the period defined in ISDU 155.

#### NOTICE

The start-up current should always be slightly higher than the operating current because the drive requires more power during the acceleration phase than when running at a constant speed.

#### NOTICE

If small torque limits are to be used, the following must be considered: Small operating torque values should not be used in combination with high speed settings as this can lead to an instable positioning behaviour!

#### 4.5. Behaviour in case of blocking

If, during the run, the achievable speed falls below the limit value of 30 % of the selected maximum speed (ISDU 143) for longer than 200 ms (ISDU 154) (these are the default values), the device registers an obstruction, aborts the run and sets the “positioning error” bit. The drive then comes to a standstill with the selected holding torque (ISDU 150).

After this, new run commands can be sent without taking further measures, i.e. transferring a new target position starts a new positioning run.

An exception is when the target value is the same as before. In this case, the release bit must first be cleared and then set again (bit 4 in the command byte). The drive then continues to run when the release bit is set. Bit 2 (“transfer target value”) must also be set.

#### CAUTION!

Runs which intentionally involve a run to an obstruction (e.g. reference runs to a block) may only be started with a reduced current (max. operating current < 10 % of nominal rated current or smallest possible value).

#### 4.6. Behaviour if the drive is turned manually (readjustment function)

If the PSD4xxIO is rotated in the direction opposite to that of the loop direction – when at a standstill, after a correctly completed positioning run and the release bit (bit 4 in the control word) is set and ISDU 126 is set to 1 – it will again attempt to run to the previously sent target value (readjustment). After successful readjustment bit 0 will be set again.

The device does not attempt to readjust if rotated in the direction to that of the loop direction, it will merely set bit 11 of the status byte (“Manual displacement”) and reset bit 0 (“Target position reached”). If the loop length (ISDU 124) is set to 0, the drive readjusts in both directions.

#### NOTICE

If the drive continually loses its position when at a standstill, it will attempt to readjust whenever its actual position just leaves the positioning window (provided that all of the above-mentioned conditions are met). At this time, the motor voltage must be within the permissible range (i.e. bit 4 in the status word is set). No readjustment will start if the motor voltage is not in the permissible range. Instead, bits 10 (“Positioning error”) and 13 (“Motor power was missing”) will be activated. If the motor voltage only returns to the permissible range after leaving the positioning window, **no** new readjustment attempt will start. This prevents a situation in which the drive suddenly starts to move when the motor voltage is switched on.

If a positioning run or manual run is aborted while in progress by a stop command (“Release” bit in command byte to 0), the drive will only readjust when a new run command is sent and completed correctly.

Resetting the release bit and/ or setting ISDU 126 to 0 can completely prevent the readjustment process.

Drives with brakes never have a readjustment function.



#### 4.7. Calculate the absolute physical position

The PSD4xxIO actuator includes an absolute measuring system capable of covering a range of 4026 rotations. This allows the user to determine the direction of rotation for any desired portion of these 4026 rotations.

The mapping of the desired positioning range to the physical positioning range “mapping end” is performed via ISDU 120.

#### NOTICE

The following explanations concern the variants without auxiliary gearbox. For variants with auxiliary gearbox, the specified numerical values are reduced accordingly.

When it is delivered the drive is positioned at 0, the upper limit switch is positioned at 805,200, the lower limit switch positioned at -805,200. This results in a positioning range of  $\pm 2013$  rotations ( $\pm 805,200$  steps). If the desired positioning range does not exceed  $\pm 2013$  rotations, none of the steps described below are required to set the positioning range in the delivery state.

The following two options are available to allow you to realise any desired positioning run distances independently of the run distance set by the mounting orientation of the measurement system (physical positioning range):

- 1) Bring the axle to be moved (e.g. a spindle) into the desired position, run the drive to the appropriate position with the adjustable collar open and only then close the adjustable collar.

#### Examples:

- a) Bring the axle to be positioned into the mid-position, run the drive in neutral (with the adjustable collar open) to the mid-position (position 0), then close the adjustable collar. The drive can now run 2,013 rotations in both directions (default  $\pm 805,200$  steps).
  - b) Bring the axle to be positioned all the way to the left (or bottom), run the drive in neutral (with the adjustable collar open) without a loop to the smallest position (position -805,200), then close the adjustable collar. The drive can now run 4,026 rotations to the right (or top) (default 1,610,400 steps).
  - c) Bring the axle to be positioned all the way to the right (or top), run the drive in neutral (with the adjustable collar open) to the largest position (position 805,200), then close the adjustable collar. The drive can now run 4026 rotations to the left (or bottom) (default 1,610,400 steps).
- 2) Mount the drive in the required position on the axle, close the adjustable collar, then adjust the positioning range using ISDU 120. ISDU 120 sets the upper end of the positioning range. Default setting: upper end at +2016 rotations (position 806,400). If, after mounting the drive, the positioning range does not match the currently displayed position, you can select the positioning range between +3...+4029 rotations (measured from the current position) as required.

**Examples:**

- a) After mounting the drive, the position 0 is displayed (which corresponds to the delivery state). The positioning range should point exclusively to the right (or top)
  - Upper mapping end = position + 4029 rotations
  - Set ISDU 120 to 1,611,600.
- b) After assembly, the displayed position is 804,000. However, the positioning range should point exclusively to the right (or top).
  - Upper mapping end = position + 4029 rotations
  - Set ISDU 120 to 2,415,600.
- c) After assembly, the displayed position is -804,400. However, the positioning range should point exclusively to the left (or bottom)
  - Upper mapping end = position +3 rotations
  - Set ISDU 120 to -803,200.

**Notes:**

- 1) When calculating the upper mapping end (ISDU 120) (as in the above examples), it is essential to include a safety margin of 3 rotations (by default 1,200 increments), because the highest possible position value is 3 rotations below the upper mapping end. The smallest possible position value is 4,029 rotations below the upper mapping end.
- 2) The numbers of increments or position values indicated relate to the following settings, which correspond to the delivery state:
  - a) Referencing value (ISDU 119) = 0
  - b) Actual value of numerator (ISDU 116) = 400
  - c) Actual value of denominator (ISDU 117) = 400

These 3 ISDUs affect the above numbers of increments or position values: The referencing value can be used to shift the range of values, the numerator/denominator to stretch or extend the range of values (see below).

- 3) If the direction of rotation (ISDU 115) is changed, the referencing value (ISDU 119), the upper mapping end (ISDU 120) and the upper and lower limit switches (ISDU 121 and 122) will be reset to the delivery states.
- 4) If the upper mapping end (ISDU 120) is changed, the upper and lower limit switches (ISDU 121 and 122) will be reset to the delivery states.
- 5) If the actual value assessment (numerator; ISDU 116 or denominator; ISDU 117) is changed, the target value, actual value, referencing value, upper mapping end, upper and lower limit switches, positioning window and loop length will be recalculated.
- 6) If the referencing value (ISDU 119) is changed, the target value, actual value, upper mapping end and the upper and lower limit switches will be recalculated.

## Functions

- 7) If the user wants to avoid any automatic adjustment of values when setting the parameters for the drive, the optimum order for sending the parameters is as follows:
  - a) Direction of rotation (ISDU 115),  
actual value assessment of numerator (ISDU 116),  
actual value assessment of denominator (ISDU 117)
  - b) Referencing value (ISDU 119)
  - c) Upper mapping end (ISDU 120)
  - d) Upper limit switch (ISDU 121),  
Lower limit switch (ISDU 122),  
Positioning window (ISDU 123),  
Loop length (ISDU 124)
- 8) To save the settings permanently in EEPROM write a 1 in ISDU 194. As soon as reading ISDU 194 returns a 0, the settings have been saved.

### Referencing value (ISDU 119):

With the referencing value (ISDU 119) a shift of the entire value range can be achieved. The referencing process affects all transferred values, i.e., the target value, actual value, upper mapping end and upper and lower limit switches.

There are two ways of setting the referencing value:

- 1) Directly – by writing the referencing value in ISDU 119.
- 2) Indirectly – by writing an actual value to ISDU 68. This makes it possible to assign any “true” actual value to the current, physical actual value. The resulting difference is then the referencing value. This value will immediately be included in calculations for each transferred value and can also be read under ISDU 119.

If the referencing value is changed, the target value, actual value, upper mapping end and the upper and lower limit switches will be recalculated.

## NOTICE

Removal of the supply voltage to the **motor** has no effect on the internal measurement system.

#### 4.8. Use of the “Upper mapping end” parameter

The following chapter illustrates the use of the parameter “upper mapping end” both graphically and by means of examples:

##### a) Delivery state

In the delivery state (“DS”), the actual position is exactly in the middle of the positioning range. There is a safety margin of three rotations at the output shaft at both the lower and upper ends of the positioning range.

Positioning runs that extend into these safety margins are rejected by the device with the error “Incorrect target value”.

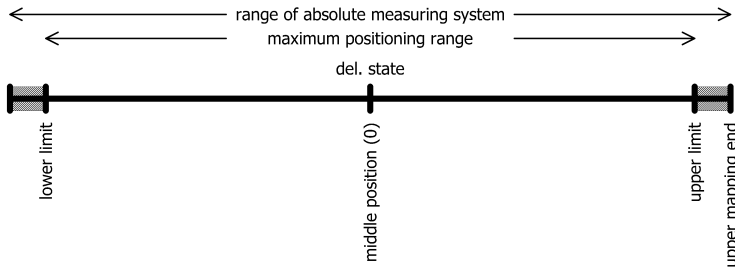

In the delivery state, the values from the following table result for the upper mapping end and the lower and upper limits:

Device type	PSD 401/411, 422/432, 480/490	PSD 403/413, 481/491	PSD 424/434	PSD 426/436	PSD 428/438
Measurement range of the absolute measuring system	4,032 rotations	992 rotations	1,944 rotations	1,280 rotations	983 rotations
Max. possible positioning range	4,026 rotations	986 rotations	1,938 rotations	1,274 rotations	977 rotations
Upper mapping end	806,400	198,498	388,800	256,000	196,683
Lower limit	-805,200	-197,298	-387,600	-254,800	-195,483
Upper limit	805,200	197,298	387,600	254,800	195,483

##### Positioning range symmetrical to 0

Starting from this state, the maximum possible positioning range can now be shifted upwards or downwards as required.

It is important to note that after the device has been installed, the available positioning range may not be sufficient in one of the two directions. The parameter “upper mapping end” now allows you to reduce the positioning range in one direction and increase it in the other direction.

**b) Shifting the positioning range upwards starting from the delivery state**

In the following example, starting from the DS, the maximum possible positioning range is shifted slightly **upwards** using the parameter “upper mapping end” (example for a PSD401/411, PSD422/432 or PSD480/490):

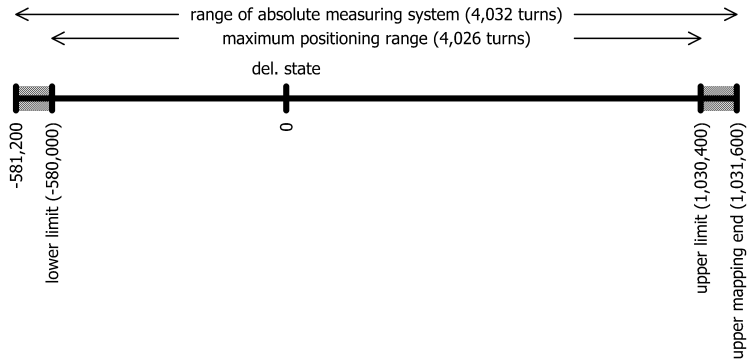

Here, the upper mapping end was increased from the value 806,400 to 1,031,600. Consequently, a higher proportion of the possible positioning range is in the positive range and a smaller proportion in the negative range.

In the extreme case, the upper mapping end can be set so that the entire possible positioning range is at values  $\geq 0$ . With standard scaling (numerator = denominator = 400, i.e. 1 step =  $0.9^\circ$ ) and referencing value = 0, this special case results if the relevant value from the following table is selected for the upper mapping end. The device then automatically adjusts the lower and upper limits accordingly.

Device type	PSD 401/411, 422/432, 480/490	PSD 403/413, 481/491	PSD 424/434	PSD 426/436	PSD 428/438
Measurement range of the absolute measuring system	4,032 rotations	992 rotations	1,944 rotations	1,280 rotations	983 rotations
Max. possible positioning range	4,026 rotations	986 rotations	1,938 rotations	1,274 rotations	977 rotations
Upper mapping end	1,611,600	395,796	776,400	510,800	392,166
Lower limit	0	0	0	0	0
Upper limit	1,610,400	394,596	775,200	509,600	390,966

Positioning range starts at 0

Illustration of this extreme case for a PSD401/411, PSD422/432 or PSD480/490:

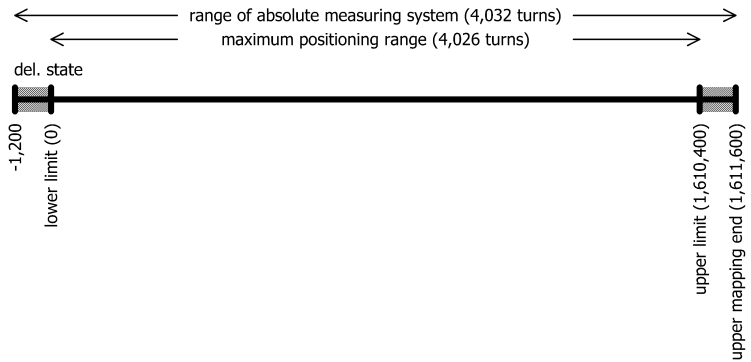

## NOTICE

The numerator factor and denominator factor can be used to map any spindle resolutions. Using the referencing value, you can shift the whole range of values.state is 00; the PSD4xx identifies itself using address 1 at the bus.

### c) Shifting the positioning range downwards starting from the delivery state

In the following example, starting from the DS, the maximum possible positioning range is shifted slightly **downwards** using the parameter “upper mapping end” (example for a PSD401/411, PSD422/432 or PSD480/490):

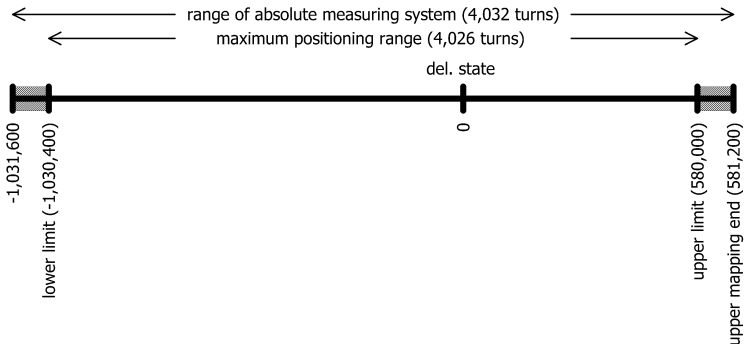

Here, the upper mapping end was decreased from the value 806,400 to 581,200. Consequently, a higher proportion of the possible positioning range is in the negative range and a smaller proportion in the positive range.

In the extreme case, the upper mapping end can be set so that the entire possible positioning range is at values  $\leq 0$ . With standard scaling (numerator = denominator = 400, i.e. 1 step = 0.9°) and referencing value = 0, this special case results if the relevant value from the following table is

## Functions

selected for the upper mapping end. The device then automatically adjusts the lower and upper limits accordingly.

Device type	PSD 401/411, 422/432, 480/490	PSD 403/413, 481/491	PSD 424/434	PSD 426/436	PSD 428/438
Measurement range of the absolute measuring system	4,032 rotations	992 rotations	1,944 rotations	1,280 rotations	983 rotations
Max. possible positioning range	4,026 rotations	986 rotations	1,938 rotations	1,274 rotations	977 rotations
Upper mapping end	1,200	1,200	1,200	1,200	1,200
Lower limit	-1,610,400	-394,596	-775,200	-509,600	-390,966
Upper limit	0	0	0	0	0

### Positioning range ends at 0

Illustration of this extreme case for a PSD401/411, PSD422/432 or PSD480/490:

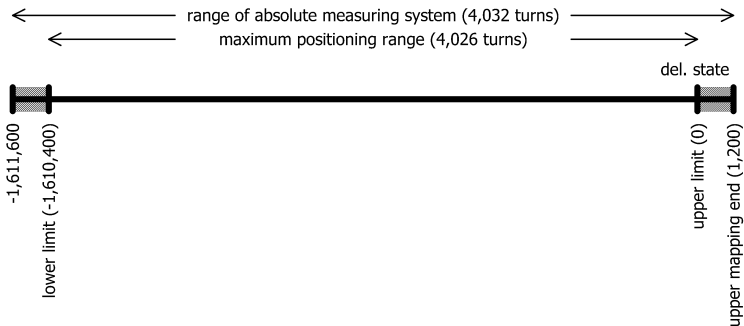

**d) Shifting the positioning range depending on the actual position**

If (in contrast to the examples above) the actual position is not in the delivery state (i.e. value 0), this is included in the calculation of the possible value range for the upper mapping end. The decisive factor is that the device only accepts values for the upper mapping end where the actual position is within the max. possible positioning range after the upper mapping end has been set (due to rounding effects with a max. difference of 1 step), i.e. the following applies after setting the upper mapping end:

$$[lower\ limit - 1] \leq actual\ position \leq [upper\ limit + 1]$$

Please note that the measurement range of the absolute encoder is 4,032 rotations at the motor shaft. Depending on the ratio of the auxiliary gearbox, the measurement range at the output shaft is reduced accordingly. Together with the safety margins at the upper and lower end of the measurement range, the following value ranges result for the upper mapping end:

$$Minimum\ value\ for\ upper\ mapping\ end = actual\ position + 1200 * denominator / numerator$$

$$Maximum\ value\ for\ upper\ mapping\ end = actual\ position + a * denominator / numerator$$

The variable a differs between the individual device variants:

Device type	PSD 401/411, 422/432, 480/490	PSD 403/413, 481/491	PSD 424/434	PSD 426/436	PSD 428/438
Variable a	1,611,600	395,797	776,400	510,800	392,166

The following formulas result for the special case numerator = denominator:

$$Minimum\ value\ for\ upper\ mapping\ end = actual\ position + 1200$$

$$Maximum\ value\ for\ upper\ mapping\ end = actual\ position + a$$

(This is the case, e.g. for the delivery state where numerator = denominator = 400.)

**NOTICE**

Since the upper mapping end is an integer, the minimum and maximum values are obtained by rounding to the nearest integer (applies only to the case numerator ≠ denominator).



**Example:**

- Spindle with 5 mm pitch, specified unit for target and actual values: 1  $\mu\text{m}$   
→ 1 rotation = 5 mm = 5,000 m  
→ Number of steps per rotation = 5,000
- Using the formula  
*Number of steps per rotation = 400 \* denominator / numerator*  
the following result is obtained:  
numerator = 400; denominator = 5,000
- With these settings, the drive is mounted and run using manual positioning commands, to a defined physical position (e.g. a specific mark along the run path) at which the actual position is to assume a specific value, e.g. the value 0.
- In our case, the position after running to this defined physical position shows, for example, the value 300,000. In this position, the actual value is set to zero. The device uses this information to calculate the new referencing value at 300,000.  
→ Referencing value = 300,000
- The drive (in our case a PSD401, PSD411, PSD422, PSD432, PSD480 or PSD490) has a positioning range of 4,026 rotations (see above: Measurement range of the absolute encoder minus a safety margin of three rotations at both ends of the measurement range).
- In our case, these 4,026 rotations are to be divided in such a way that the drive can run 10 rotations (= 10 \* 5,000 steps = 50,000 steps) from the zero position, just defined, to smaller values and 4,016 rotations (= 4,016 \* 5,000 steps = 20,080,000 steps) to larger values.
- To ensure that the position value 20,080,000 is at the upper end of the maximum possible positioning range, as specified (i.e. at the upper limit), we add the safety margin of three rotations to this value and thus obtain our value for the upper mapping end:  
upper mapping end = 20,080,000 + 3 \* 5,000 = 20,095,000
- The device then recalculates the positioning range limits:  
lower limit = upper mapping end - 4,029 \* 5,000 = -50,000  
upper limit = upper mapping end - 3 \* 5,000 = 20,080,000
- This positioning range can then be restricted as required, i.e. the lower limit can be increased and the upper limit can be reduced.

**e) Step-by-step instructions for determining the positioning range**

The following section describes the procedure for determining those parameters that have an influence on the target and actual position as well as the positioning range.

The individual steps must be carried out in the specified order.

**1) Setting the direction of rotation:**

The direction of rotation determines with which direction of rotation of the output shaft the position values increase and with which direction of rotation of the output shaft the position values decrease.

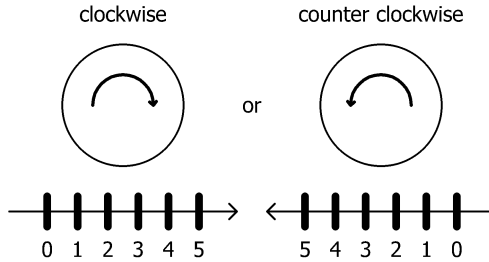

**2) Setting numerator and denominator:**

The numerator and denominator determine the number of steps into which one rotation of the output shaft is divided.

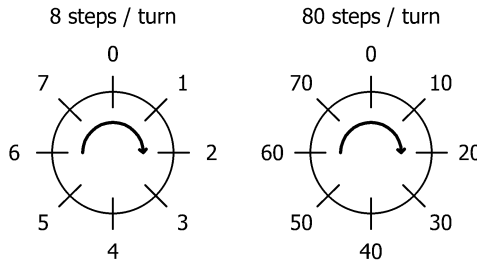

**3) Setting referencing value:**

The referencing value is used to assign a specific value of the actual position to a specific physical position of the axle.

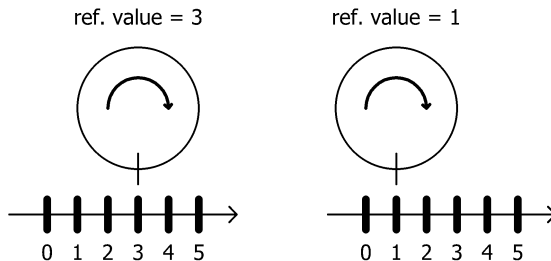

The referencing value is written either directly or by setting the actual position.

Functions

**4) Setting upper mapping end:**

The parameter defines the location of the maximum possible positioning range in relation to the actual position.

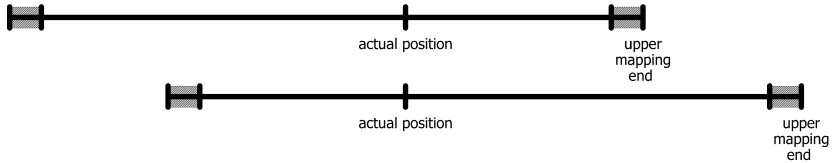

**5) Setting upper and lower limits:**

If necessary, the maximum possible positioning range can be restricted to prevent incorrect target positions that lead to a collision.

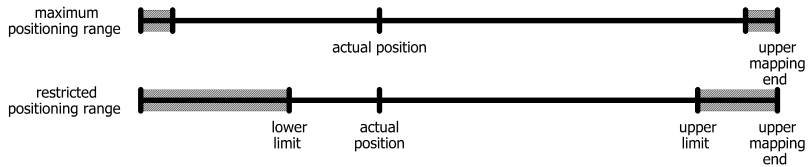

#### 4.9. Set the spindle pitch

ISDU 116 (numerator factor) and 117 (denominator factor) can be used to modify the instrument's spindle resolutions to any desired numerical value:

$$\text{Number of increments per rotation} = 400 \times \frac{\text{Denominator factor}}{\text{Numerator factor}}$$

Both factors are set to a value of 400 by default, resulting in a resolution of 0.01 mm at a spindle pitch of 4 mm.

The denominator factor is a simple way to set the spindle pitch and resolution.

The numerator factor is primarily used for setting "unlevel" resolutions.

**Examples:**

Spindle pitch	Resolution	Numerator factor	Denominator factor
4 mm	1/100 mm	400	400
1 mm	1/100 mm	400	100
2 mm	1/10 mm	400	20

#### NOTICE

Numerator and denominator factors may take on values between 1 and 10,000.

#### 4.10. Modulo function

(Available from firmware V19 for variants with the feature “Software modules” = “M” or “Z”)

##### Operating principle:

The modulo function allows the user to have the device process the transmitted target position as a modulo position instead of as a continuous target position. This can be used to cover applications in which, for example, it is driving a **turntable**.

The user specifies a range for target and actual values, as in normal operation. In modulo mode, the limits of this range are called “Lower modulo position” or “Upper modulo position”. The special feature of the modulo mode is that the modulo range repeats infinitely upwards and downwards, i.e. in this operating mode there are no limits to the positioning range – thus it is possible to make an infinite number of positioning runs in the same direction.

A characteristic feature of these applications is that after a certain distance, the entire arrangement is back in its initial state. e.g. for a turntable, where the axle is driven directly (i.e. without a gearbox), this would be the case after exactly one turn of the turntable.

The distance after which the arrangement is back in the initial state is called the “modulo width”. The modulo width is determined by specifying the parameters “Upper modulo position” and “Lower modulo position”:

$$\text{Modulo width} = \text{Upper modulo position} - \text{Lower modulo position}$$

The modulo mode distinguishes between five sub-modes; the following parameters are therefore relevant for the modulo function:

- 1) Modulo mode (ISDU 184)
- 2) Upper modulo position (ISDU 185)
- 3) Lower modulo position (ISDU 186)

##### Processing the target position in modulo mode:

When the modulo function is activated, the target position is placed in the modulo range – taking into account the modulo width – in such a way that the difference between the transmitted target position and the position actually approached is an integer multiple of the modulo width.

##### Example:

- Upper modulo position = 360 (ISDU 185)
- Lower Modulo position = 0 (ISDU 186)
- Transmitted target position = 450 → Device runs to position 90.

##### Calculation of the actual position:

Likewise, the device outputs the actual position so that the value is always within the modulo range:

$$\text{Lower modulo position} \leq \text{Actual position} < \text{Upper modulo position}$$

The following rules apply:

- When the value for the actual position increases, the actual position jumps to the value “Lower modulo position” as soon as the value [Upper modulo position - 1] is exceeded.

- When the value for the actual position decreases, the actual position jumps to the value [Upper modulo position - 1] as soon as the value falls below the value “Lower modulo position”.

**Activation of modulo mode:**

Modulo mode is activated or deactivated by setting ISDU 184 (“Modulo mode”). The parameter can assume the following states:

- 0 → Modulo function inactive (this is the default value)

The transferred target position is processed as a continuous target position.

- 1 → Run to larger values

In this mode, the device runs exclusively in the direction of larger values.

When the value [Upper modulo position - 1] is exceeded, the actual value jumps to the value [Lower modulo position]. The maximum run distance corresponds to the distance [Modulo width - 1].

- 2 → Run to smaller values

In this mode, the device runs exclusively in the direction of smaller values.

When the value falls below the value [Lower modulo position], the actual value jumps to the value [Upper modulo position - 1]. The maximum run distance corresponds to the distance [Modulo width - 1].

- 3 → Shortest distance

In this mode, the device selects the direction required to run to the specified target position by the shortest distance. The maximum run distance corresponds to the half modulo width.

- 4 → Run to larger values, with blocking zone

This mode is the same as the “Run to larger values” mode with the following exception: if the distance of a run is smaller than or equal to the positioning window when moving to smaller values, the drive runs to the desired target position at smaller values.

- 5 → Run to smaller values, with blocking zone

This mode is the same as the “Run to smaller values” mode with the following exception: if the distance of a run is smaller than or equal to the positioning window when moving to larger values, the drive runs to the desired target position at larger values.

**NOTICE**

Modes 4 and 5 are useful when a new run command to the actual position is issued. In contrast to modes 1 and 2, a slight drifting of the actual position in these modes does not lead to an unintended run by almost a whole modulo width.

**Other settings:**

The other settings that influence the positioning process (in particular, the direction of rotation, scaling, referencing value, positioning window and activation of the adjustment function) retain their previous function in modulo mode, but the following exceptions apply:

- The positioning range limits and the upper mapping end have no function in modulo mode.
- In modulo mode, there is generally no reference loop. However, the sign of the loop length (ISDU 124) also defines the direction from which adjustment is performed in modulo mode.

**Manual run in modulo mode:**

When modulo mode is activated (i.e. modulo mode > 0), the drive moves exactly one modulo width starting from the actual position. This applies regardless of the direction specified by the modulo operating mode:

- Manual run to larger values → The drive runs one modulo width to larger values.
- Manual run to smaller values → The drive runs one modulo width to smaller values.

**NOTICE**

The ISDUs 184-186 are available from firmware V19.

For variants with the "Modulo function" option (i.e. variants with the feature "Software modules" = "M" or "Z"), the modulo function is configured with these ISDUs.

For variants without the "Modulo function" (i.e. variants with the feature "Software modules" = "1", "S" or "P"), only the default value can be written, other values are rejected.

#### 4.11. Changeover of parameter set

(Available from firmware V19 for variants with the feature “software modules” = “S” or “Z”)

Some parameters that have an influence on the execution of a positioning run are stored in the device in four instances. The associated ISDUs have 4 sub-indices, resulting in a total of four run sets. Values with the same sub-index are thus combined in a “parameter set”.

The desired run set is selected using bits 8 and 9 of the command byte:

- Bits 9..8 = 0x00 → Run set 1 (Sub-index 1)
- Bits 9..8 = 0x01 → Run set 2 (Sub-index 2)
- Bits 9..8 = 0x02 → Run set 3 (Sub-index 3)
- Bits 9..8 = 0x03 → Run set 4 (Sub-index 4)

The following parameters are included in the changeover of parameter set feature, i.e. switching the run set causes the values from the corresponding sub-index to be applied immediately (i.e. either during a current positioning run or, at the latest, during the next positioning run) for the following ISDUs:

- ISDU 123: Positioning window
- ISDU 137: Target speed for positioning runs
- ISDU 138: Target speed for manual runs
- ISDU 139: Acceleration 1
- ISDU 141: Deceleration 1
- ISDU 143: Speed limit for run abort
- ISDU 147: Max. start-up current \*)
- ISDU 148: Max. operating current
- ISDU 149: Max. holding current at end of run
- ISDU 150: Max. holding current
- ISDU 154: Time elapsed until speed falls below speed limit for run abort
- ISDU 155: Time period for start-up current \*)
- ISDU 157: Duration of max. holding current at end of run

The run set can also be changed while a positioning run is in progress, e.g. the target speed or operating current can be adjusted to new conditions without having to execute an ISDU request (e.g. in the event of a load change). Usually, the run sets are stored once in the EEPROM of the device or transferred to the device when communication is established before the first run command.

If the parameter set is changed during an ongoing positioning run, changes to the parameters marked with \*) only become effective during the next positioning run. Changes to all other parameters are already effective during the ongoing positioning run.

#### NOTICE

In the case of variants without the changeover of parameter set feature (i.e. variants with the feature “Software modules” = “1”, “M” or “P”), bits 9..8 have no function and are ignored by the device.



#### 4.12. Aborted run when the master fails

If the connection to the master is interrupted during a positioning run, the master cannot abort a run that is already underway.

**In this case, there are two possible responses:**

- 1) If a positioning run is in progress, the drive should **complete this positioning run as planned**. It should then not start any new positioning run until a connection has been re-established.
  - This response is activated when ISDU 162 ("Communication timeout") is set to 0.
- 2) If a positioning run is in progress, the drive should **abort this positioning run**. It should then not start any new positioning run until a connection has been re-established.
  - This response is activated when ISDU 162 ("Communication timeout") is set to a value > 0. The value specifies the time (in ms) within which a new master telegram must be received in order to maintain the connection.

### 4.13. Reference runs

The PSD4xxIO positioning system is equipped with an absolute measuring system, so no reference run is required when the drive is switched on. If a reference run should be required to a hard obstruction in a specific instance (e.g. once during installation of the drive on a machine), the procedure should be as follows:

- 1) Prior to ordering the reference run, adjust the settings as follows:
  - Set the max. operating current (ISDU 148) and max. start-up current (ISDU 147) to a maximum of 10 % of the nominal rated current, resp. the lowest possible values
  - Set the holding current (ISDU 150) and max. holding current at end of run (ISDU 149) to 0
  - Set the speed limit (rpm) for run abort (ISDU 143) to 60
  - Set the time for falling below the speed limit (rpm) for run abort (ISDU 154) to 100. (The time during which the drive tries to overcome the obstruction decreases: with these reduced values, the positioning run is aborted if the speed (rpm) remains below 60% of the target speed for longer than 100 ms. The default settings are 200 ms and 30 %.)
  - Set the affected end limit (ISDU 121 or 122) so that the obstruction is clearly within the limit in each case (Otherwise there is a risk that the obstruction will lie within the positioning window and therefore not be recognised.)
  - If necessary, reduce the target speed for manual operation (ISDU 138)
- 2) Now start the reference run as a manual run (bit 0 or 1 in the command byte).
- 3) Wait until the drive is running (bit 6 is set in the status byte)
- 4) Wait until the drive is stationary and a positioning error has occurred (bit 6 of the status byte is reset, bit 10 is set).
- 5) Using the same settings, perform a manual run in the opposite direction (move a little distance away from the obstruction so the drive can move freely).
- 6) Only now use desired settings for normal operation of the above ISDUs.

### 4.14. Saving parameters

Changes to parameters are not automatically saved in the drive. To retain the modified values after switching off and on again, a save command must be sent to the drive. This is possible by sending the standard command (ISDU 2) with value 161, or by writing value 1 to the delivery status (ISDU 194).

#### NOTICE

The automatic sending of default values after a restart must not be activated in the control unit!

**4.15.Run drive in reverse**

Depending on the model, the drive may be run in reverse up to a certain speed.

**⚠ CAUTION!**

Running a PSD4xx in reverse for more than 1-2 seconds at more than the permissible speed will damage the internal protection diode and the PSD4xx will be defective.

Please refer to the following table to find the maximum permissible speed:

Device model	PSD 401/411 - 5V/8H/14H	PSD 403/413 - 8H/14H	PSD 422/432 - 8V/8H/14H	PSD 424/434 - 14H	PSD 426/436 - 14H
Max. permissible speed [rpm]	200	48	200	95	60

Device model	PSD 428/438 - 14H	PSD 480/490 - 5V	PSD 480/490 - 8H/14H	PSD 481/491 - 8H/14H
Max. permissible speed [rpm]	45	200	200	48

## 5. Technical data

Technical data and drawings can be found in the current data sheet on the website:  
[www.halstrup-walcher.de/technicaldocu](http://www.halstrup-walcher.de/technicaldocu)

Please search for "PSD" and select your type, click on "Data sheets".

Please contact us if you require any further information.

## 6. Notes





