Instruction Manual PSE4xxC



halstrup-walcher GmbH

Stegener Straße 10
D-79199 Kirchzarten
Germany

Phone: +49 (0) 76 61/39 63-0
Fax: +49 (0) 76 61/39 63-99

E-Mail: info@halstrup-walcher.com
Internet: www.halstrup-walcher.com

Table of Contents

1	Safety precautions	4
1.1	Appropriate use.....	4
1.2	Shipping, assembly, electrical connections and startup.....	4
1.3	Troubleshooting, maintenance, repairs, disposal.....	4
1.4	Symbols	5
2	Instrument description	6
2.1	Features.....	6
2.2	Mounting	6
2.3	Pin assignment.....	7
2.4	Setting the device address and baud rate	7
2.5	Start-up	8
3	The CAN bus	9
3.1	Table of entries implemented from object dictionary.....	9
	PDO definition.....	12
3.2	Detailed description of status bits	13
4	Sequence of positioning steps.....	16
4.1	Start-up reference loop.....	16
4.2	Positioning run	16
4.3	Positioning run without a reference loop.....	16
4.4	Manual run	16
5	Special features	17
5.1	Speed and acceleration.....	17
5.2	Response of drive if it encounters an obstacle or is turned manually.....	17
5.3	Calculating the absolute physical position	17
5.4	Spindle pitch.....	18
5.5	Braking when supply voltage fails during final stage (optional on the PSE42xC and the PSE43xC)	18
5.6	Automatic reference run after the loss of power to the motor.....	19
5.7	Status history	19
5.8	Drag error.....	19
6	Technical data	20
7	Dimension drawings.....	28

Purpose of instruction manual

This instruction manual describes the features of the PSE4xxC positioning system and provides guidelines for its use.

Improper use of these instruments or failure to follow these instructions may cause injury or equipment damage. All individuals responsible for operating these instruments must therefore be properly trained and aware of the hazards, and must carefully follow these operating instructions and the safety precautions detailed within. **Contact the manufacturer if you do not understand any part of this instruction manual.**

Handle this manual with care:

- It must be readily available throughout the lifecycle of the instruments.
- It must be provided to any individuals who assume responsibility for operating the instrument at a later date.
- It must include any supplementary materials provided by the manufacturer.

The manufacturer reserves the right to continue developing this instrument model without documenting such development in each individual case. The manufacturer will be happy to determine whether this manual is up-to-date.

Conformity

This instrument corresponds to the state of the art and meets all legal requirements set forth in EC directives as evidenced by the CE label.



© 2005

The manufacturer owns the copyright to this instruction manual. This manual contains data, instructions and drawings pertaining to the features and usage of these instruments; copying this manual in part or in full or distributing it to third parties is prohibited.

1 Safety precautions

1.1 Appropriate use

Positioning systems are especially suitable for automatically setting tools, stops or spindles for wood-processing equipment, packing lines, printing equipment, filling units and other types of machines.

PSE4xxC positioning systems are not stand-alone instruments and may only be used if coupled to another machine.

Always observe the operating requirements—particularly the permissible supply voltage—indicated on the rating plate and in the "Technical data" section of this manual.

The instrument may only be handled as indicated in this manual. Modifications to the instrument are prohibited. The manufacturer is not liable for damages caused by improper use or failure to follow these instructions. Violations of this type render all warranty claims null and void.

1.2 Shipping, assembly, electrical connections and startup

Only technical personnel who are appropriately trained and authorized by the operator of the facility may assemble the instrument and set up its electrical connections.

The instrument may only be operated by appropriately trained individuals who have been authorized by the operator of the facility.

Specific safety precautions are given in individual sections of this manual.

1.3 Troubleshooting, maintenance, repairs, disposal

The individual responsible for the electrical connections must be notified immediately if the instrument is damaged or if errors occur.

This individual must take the instrument out of service until the error has been corrected and ensure that it cannot be used unintentionally.

This instrument requires no maintenance.

Only the manufacturer may perform repairs that require the housing to be opened.

The electronic components of the instrument contain environmentally hazardous materials and materials that can be reused. For this reason the instrument must be recycled in accordance with the environmental guidelines of the jurisdiction in question once it has been taken permanently out of service.

1.4 Symbols

The symbols given below are used throughout this manual to indicate instances when improper operation could result in the following hazards:



WARNING! This warns you of a potential hazard that could lead to bodily injury up to and including death if the corresponding instructions are not followed.



WARNING: This warns you of a potential hazard that could lead to significant property damage if corresponding instructions are not followed.



INFORMATION This indicates that the corresponding information is important for operating the instrument properly

2 Instrument description

2.1 Features

PSE4xxC positioning systems are intelligent, compact, complete solutions for positioning auxiliary and positioning axes, and consist of a stepping motor, gear power amplifier, control electronics and an absolute measuring system. The integrated absolute measuring system eliminates the need for a time-consuming reference run. Connecting to a bus system simplifies the wiring. A hollow shaft with adjustable collar makes assembly quite simple.

PSE4xxC positioning systems convert a digital positioning signal into an angle of rotation.

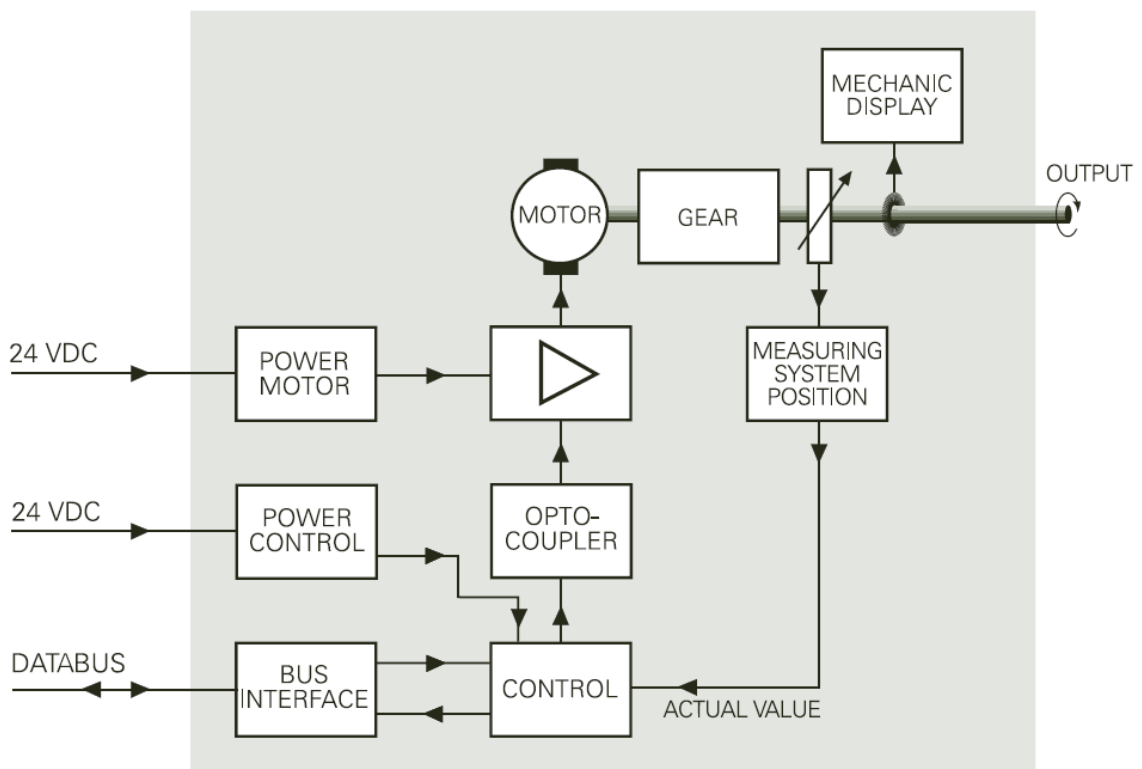

2.2 Mounting

The PSE4xxC is mounted onto the machine by sliding the hollow shaft of the positioning gear onto the axis to be driven and then securing it with an adjustable collar. The adjustable collar should be tightened only just to the point where it can no longer rotate freely.

Securing the pin under the hollow shaft into an appropriate bore will prevent further rotation (see drawing).



Never apply force to the housing cover, e.g., for supporting weight.

2.3 Pin assignment

A round, 5-pin male connector for the supply voltage and a round, 5-pin female connector for the CAN bus are located on the housing cover of the PSE4xxC. In standard pinning both are Binder series 763 connectors.

Male connector for supply:
(View from outside)

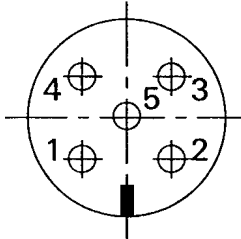

1	+24V Motor
2	GND Motor
3	+24V Control
4	GND Control
5	Case

Female connector for CAN-Bus
(View from outside)

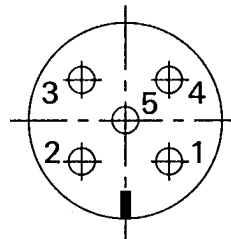

1	n. c.
2	n. c.
3	CAN_H
4	CAN_L
5	n. c.

Optional it is possible to get the CAN-Bus connector-pinning according to CiA. Then the power connector is from Binder series 766 (B-coded).

Optional Pinning:

1	+24V Motor	1	n. c.
2	GND Motor	2	n. c.
3	+24V Control	3	n. c.
4	GND Control	4	CAN_H
5	Case	5	CAN_L

2.4 Setting the device address and baud rate

Removing the protective cap provides access to two rotary switches for setting the device address at the bus and two sliding switches for setting the baud rate. The legends below describing how to set the switches are located on the interior side of the cap.

The rotary switches indicate the tens and ones places of the address selected. If these switches are set to 00 or 01, the address will be set via the CAN bus (SDO# 2026).

00 is the default setting.

The sliding switches allow the operator to set the baud rate at 125 KB, 250 KB and 500 KB or via the CAN bus (SDO# 2027).

If the switches have been used to set the address or baud rate, these values cannot be changed via the CAN bus.

Switch configurations:
PSE 40xC

PSE41xC, PSE433C, PSE 4310C, PSE4325C

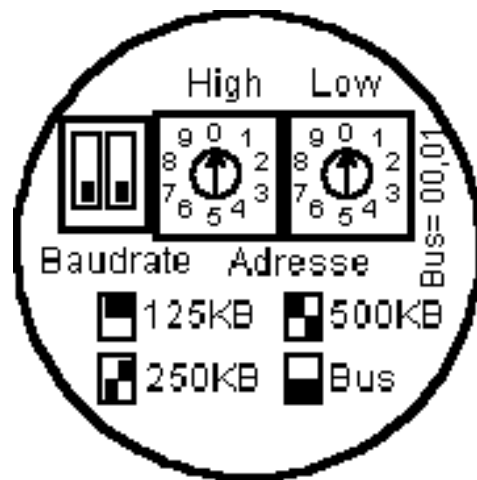
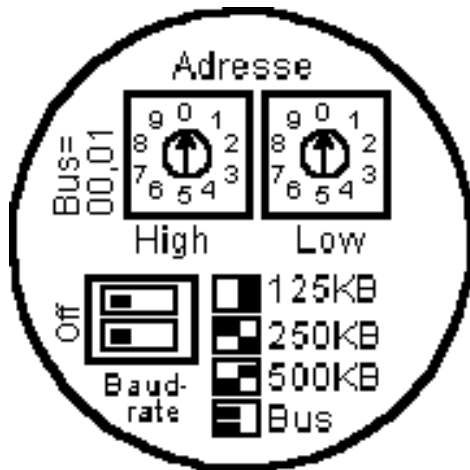

Important: Always replace the protective cap after setting the address. This will prevent dust and contaminants from entering the instrument.

2.5 Start-up

After the supply voltage has been hooked up, the PSE4xxC should be run through an initial reference loop prior to positioning, i.e., the instrument should complete half of a reverse rotation and half of a forward rotation (or vice versa, depending on the settings).

The reference loop is triggered when the corresponding command byte is transferred across the interface.

Positioning sequence (with reference loop)

The PSE4xxC distinguishes between the following steps of a positioning sequence. (It is assumed that all target positions are approached via forward motion.)

1. New position value is larger than the current value: position approached directly.
2. New position value is smaller than the current value: the instrument reverses one rotation and approaches the exact position after resuming forward motion.
3. New position value after reverse run (no reference loop): the instrument always approaches the position by moving forward one rotation; if necessary, it will first reverse by one rotation.

The instrument checks the target position once it has been reached. If the actual position differs from the target, the instrument repeats the positioning process and sets the “second positioning run required” status bit. If this second attempt also fails, it then sets the “positioning error” status bit.

Positioning sequence (without reference loop)

The “positioning without a reference loop” mode is used primarily for moving the small distances involved in fine adjustments. In this case, each position is approached directly. If the direction of rotation has been changed, the instrument will first always continue on to the desired position in order to compensate for internal gear backlash.

3 The CAN bus

CAN open (corresponding to CiA DS 301 Version 3.0) is used as the protocol at the CAN bus interface; that means not all possible functions were implemented.

(Implementation level 2.7)

Please note the following limitations:

- one transmit and one receive SDO per device
- one synchronous transmit and receive PDO, active by default (PDO 1)
- one asynchronous transmit and receive PDO, inactive by default (PDO 2)
- one emergency object
- node-guarding

3.1 Table of entries implemented from object dictionary

Name	Index number	Function	Range of values	Back up	Default setting	Access
device type	1000	returns a "0" when read	0		0	R
error register	1001	<u>Bit 0</u> : general error <u>Bit 4</u> : communication error	8 bit			R
error list	1003	sub index 0: number: 1 sub index 1: most recent error	8 bit 32 bit			R
PDO number:	1004	sub index 0: 2x sync, 2x async sub 1: sync: 1x transmit 1x receive sub 2: async: 1x transmit 1x receive	01FF01FFh 01FF01FFh 01FF01FFh			R
sync ID	1005	COB ID for the sync command	32 bit	no		R/W
comm cycle	1006	communication cycle time	32 bit	no		R/W
sync window	1007	synchronous window time	32 bit	no		R/W
device name	1008	PSE401C, PSE405C, PSE411C, PSE415C, PSE405K, PSE433C, PSE4310 or PSE4325	string7			R
hard version	1009	ID number of the PCB assembly	string7			R
soft version	100A	ID number of the software version	string7			R
guard time	100C	node-guarding is not supported	16 bit	no	0	R
life time	100D		16 bit	no	0	R
receive PDO 1 communication parameter	1400	sub index 0: index number: 4 sub 1: COB ID of this PDO sub 2: PDO type sub 3: inhibit time sub 4: CMS priority group	8 bit 32 bit 8 bit 16 bit 8 bit	no no no no	200h FFh1 0 0	R R/W R/W R/W R/W
receive PDO 2 communication parameter	1401	sub index 0: index number: 4 sub 1: COB ID of this PDO sub 2: PDO type sub 3: inhibit time sub 4: CMS priority group	8 bit 32 bit 8 bit 16 bit 8 bit	no no no no	300h FFh 0	R R/W R/W R/W R/W
transmit PDO 1 communication parameter	1800	sub index 0: index number: 4 sub 1: COB ID of this PDO sub 2: PDO type sub 3: inhibit time sub 4: CMS priority group	8 bit 32 bit 8 bit 16 bit 8 bit	no no no no	180h FFh 1 0	R R/W R/W R/W R/W
transmit PDO 2 communication parameter	1801	sub index 0: index number: 4 sub 1: COB ID of this PDO sub 2: PDO type sub 3: inhibit time sub 4: CMS priority group	8 bit 32 bit 8 bit 16 bit 8 bit	no no no no	280h FFh 0	R R/W R/W R/W R/W

Name	Index number	Function	Range of values	Back up?	Default setting	Access
	2000: 0...9	10 open registers	16 bit	yes	4096+ 9*0	R/W
target value	2001	target position to be achieved in 1/100 mm	±31 bit	yes	0	R/W
actual value	2003	current actual position in 1/100 mm writing onto this index number causes the current position to be "referenced" onto the transferred value	±31 bit	no		R/W
referencing value	2004	correction factor for the target, actual and limit switch values	±31 bit	yes	0	R/W
positioning window	2006	permissible difference between target and actual values for "position reached"	1...100	yes	1	R/W
offset index	2007	register for selecting which offsets are to be added to the target value	0...7Fh	yes	0	R/W
offset 1... offset 7	2008 ... 200E		±15 bit	yes	0	R/W
spindle pitch	2010	specifies the number of increments per rotation	10...10000	yes	200	R/W
maximum speed	2012	speed at which the instrument can approach a position (in rpm): 0 = 50 / 10 1 = 65 / 12 (at 1 / 5 Nm) 2 = 75 / 15 3 = 90 / 17	0...3	yes	3	R/W
starting speed:	2013	speed of start-up reference loop and manual run (in rpm): 0 = 12 / 2.5 1 = 25 / 5 (at 1 / 5 Nm) 2 = 40 / 7.5 3 = 50 / 10	0...3	yes	1	R/W
acceleration	2014	acceleration from initial to maximum speed (in rpm/s) 0 = 100 / 20 1 = 150 / 30 2 = 200 / 40 3 = 250 / 50 4 = 300 / 60 (at 1 / 5 Nm)	0...4	yes	2	R/W
upper limit	2016	maximum permitted target position permissible values: 0...80*spindle pitch +referencing value	±31 bit	yes	16000	R/W
lower limit	2017	minimum permitted target position permissible values: 0...80*spindle pitch +referencing value	±31 bit	yes	125	R/W
stop / emergency stop	2018	32 ends a positioning run with a ramp; 128 ends a positioning run w/o a ramp	32 or 128	no		R/W
error	2019	64: ready for a new instruction 128: emergency stop	64 or 128	no		R
command byte	2024	<u>Bit 0</u> : manual run to larger values <u>Bit 1</u> : manual run to smaller values <u>Bit 2</u> : transfer target value; positioning will only take place if this bit is set in the PDO transfer <u>Bit 4</u> : release: the axle will only move if this bit is set <u>Bit 6</u> : run without a reference loop <u>Bit 7</u> : execute initial reference loop	8 bit	no	0	R/W

Name	Index number	Function	Range of values	Back up	Default setting	Access
status	2025	<u>Bit 0</u> : position reached <u>Bit 2</u> : final stage is active <u>Bit 3</u> : start-up reference loop completed <u>Bit 4</u> : power available to motor <u>Bit 6</u> : pot. error <u>Bit 7</u> : 2 nd positioning run was necessary <u>Bit 8</u> : movement opposite loop direction <u>Bit 9</u> : PDO command received <u>Bit 10</u> : positioning error (obstruction) <u>Bit 11</u> : manual rotation <u>Bit 12</u> : incorrect target value <u>Bit 13</u> : power was unavailable to motor <u>Bit 14</u> : positive range limit <u>Bit 15</u> : negative range limit	0...FFFFh	no		R
circuit board number	2026	circuit board number is read from the EEPROM after a reset and can be overwritten.	1...127	yes	1	R/W
baud rate	2027	0: 20 kBaud 1: 125 kBaud 2: 250 kBaud 3: 500 kBaud 4: 1000 kBaud	0...4	yes	2	R/W
automatic reference run	2029	automatic reference loop and positioning run to most recent target value after power to the motor has been removed 0: off 1: on	0 or 1	yes	0	R/W
operating current	202A	0: high op. current 1: low op. current	0 or 1	yes	0	R/W
holding current	202B	0: no hold. current 1: low hold. current 2: high hold. current	0, 1 or 2	yes	2	R/W
direction of rotation	202C	0: counter clockwise (if looking at the output shaft) 1: clockwise	0 or 1	yes	0	R/W
running direction for approaching target positions	202D	0: with ½ forward rotation 1: with ½ reverse rotation	0 or 1	yes	0	R/W
idle period	202E	idle period in ms when reversing the direction of rotation	0...10000	yes	10	R/W
block mode	202F	response if an obstacle is encountered during a run: 0: abort positioning run 1: abort run and rotate 1½ times against the direction of travel	0 or 1	yes	1	R/W
actual speed	2030	Current speed in rpm. 0 = 0 1 = 12 / 2.5 2 = 25 / 5 3 = 40 / 7.5 4 = 50 / 10 5 = 65 / 12 6 = 75 / 15 7 = 90 / 17	0...7	no		R
drag error	2032	maximum difference between target and actual value appearing after the positioning run has ended	0...65535	no	0	R/W

Name	Index number	Function	Range of values	Back up?	Default setting	Access
positioning status	2034	5: no release 10: release 20: positioning run 30: manual run 40: start-up reference loop	5, 10, 20, 30 or 40	no		R
CAN status	2035	5: operational: the CAN bus can be used to read out parameters and process data 127: preoperational: the bus can only be used to read out parameters	5 or 127	no		R
CAN initialization	2037	status after booting up: 0.2: preoperational 1.3: operational SDO error messages: 0.1: on 2.3: off	0, 1, 2 or 3	yes	0	R/W
command byte 2	2038	<u>Bit 0</u> : recording history = on	0 or 1	yes	1	R/W
production date	2040	year and week of manufacture (given as an integer)	YYWW	yes		R
serial number	2041	serial device number	0...65565	yes		R
data backup/delivery state	204F	writing a "1" backs up the parameters in the EEPROM. returns a "0" if correct, or a "-1" if there has been an error. a "-1" generates the delivery state without modifying the circuit board number. a "-2" also generates the delivery state and creates a backup in the EEPROM	W: 1, -1 or -2 R: 0 or -1	no		R/W
encoder status	2501:4	counter reading of the internal encoder absolute value, 400 increments per rotation	0...32000	no	16000	R
	2503: 0...9	10 open registers (the same as in index number 2000)	see #2000			

PDO definition

- 1) Receive PDO (from the perspective of the PSE4xxC)
Address: 200h + circuit board number (possible values: 201h...27Fh)
Communication parameters: cyclic, synchronous (type "1" transmission)

Assignment (cannot be modified):

Bit	Byte	Meaning	Corresponding SDO index number
0-7	0	command byte	2024h
8-31	1-3	unused	
31-63	4-7	target value	2001h

- 2) Transmit PDO (from the perspective of the PSE4xxC)
Address: 180h + circuit board number (possible values: 181h...1FFh)
Communication parameters: cyclic, synchronous (type "1" transmission)

Assignment (cannot be modified):

Bit	Byte	Meaning	Corresponding SDO index number
0-15	0.1	status	2025h
16-31	2.3	unused	
31-63	4-7	actual value	2003h

- 3) The same assignment values apply when activating asynchronous PDOs

3.2 Detailed description of status bits

Bit 0: target position achieved

This bit is set

- when a transferred target position has been reached successfully
- after running a reference loop, when the actual value corresponds to the previously transferred target value

This bit is deleted

- after transferring a target position when the difference from the actual value is larger than the positioning window (SDO no. 2006)
- by a manual run
- any time the “start-up reference loop completed” bit is deleted

Bit 2: final stage is active

This bit is set

- when the drive is rotating
- when the system is on standstill, a holding current has been programmed and there is power available to the motor

This bit is deleted

- when the system is on standstill and the holding current has been programmed to 0
- if no power is available to the motor

Bit 3: start-up reference loop completed

This bit is set

- after a start-up reference loop has been successfully completed (no further runs may be executed if an obstacle is encountered during this reference loop)

This bit is deleted

- after the instrument is switched on
- when a start-up reference loop is started
- if “emergency stop” is transmitted during a positioning run (does not apply to emergency stop status and when the motor is idle)
- if the drive is blocked during a positioning run
- if the output shaft is turned manually by more than 18° while the drive is on standstill
- if the spindle pitch, direction of rotation or the running direction for target positions is modified
- if a potentiometer error occurs (see bit 6)
- when the “generate delivery state” command is executed

Bit 4: power supply to motor available

This bit is set

- if the supply voltage for the motor is in place

This bit is deleted

- if the supply voltage for the motor is not in place

Bit 6: potentiometer error

This bit is set

- if, after 100 measurement attempts, no 3 consecutive measurements were the same during the A/D potentiometer conversion at the end of a positioning run or start-up reference loop. (This could be caused, for example, by overly strong EMC interference.)
- no runs may be executed afterwards (drive must be removed from the power supply)

This bit is deleted

- after the instrument is switched on

Bit 7: 2nd positioning run was necessary

This bit is set

- if, when checking the actual value at the end of a positioning run, the instrument determines that the difference between the target and actual value was larger than the positioning window, necessitating a second positioning run
- a difference of more than 18° at the output shaft (= over 0.1 mm at the sliding carriage for a 2 mm spindle) results in a positioning error regardless of the positioning window.

This bit is deleted

- before the first positioning attempt of a new positioning run

Bit 8: movement in reverse loop direction

This bit is set

- during a manual run in the direction opposite that of the positioning run.
A subsequent manual run in the direction of the positioning run will not delete this bit.
- during a positioning sequence in the direction opposite that of the reference loop

This bit is deleted

- when a transferred target position has been reached successfully (in the direction of the reference loop)
- after the start-up reference loop

Bit 9: PDO run command received (toggle bit) is deleted after the instrument is switched on.

This bit is changed

- by transmitting a PDO with a control bit or a target value differing from the previous values when the “transferring target value” bit is set.

Bit 10: Positioning error (obstruction)

This bit is set

- if the theoretical actual value (derived from the number of motor steps counted) and the true actual value (the encoder reading at the output shaft) differ from each other during a positioning or manual run by more than 18° at the output shaft (for a 2mm spindle = more than 0.1 mm at the sliding carriage). Short rough stretches encountered during positioning runs generally cause the motor to stop, resulting in a positioning error. This happens because the stepping motor is being operated above its start/stop speed and cannot continue, even once the rough stretch has been cleared, without a new speed ramp. For manual runs, the speed is always below the start/stop speed of the stepping motor; as a result, the drive could encounter a small obstacle without necessarily generating a positioning error. The “start-up loop completed” bit is deleted as soon as a positioning error is registered.

This bit is deleted

- after a start-up reference loop has been correctly executed

Bit 11: Manual rotation

This bit is set

- if the output shaft is turned manually by more than 18° (for a 2 mm spindle = a difference of over 0.1 mm at the sliding carriage) while the drive is on standby and when a supply voltage is available. The “start-up loop completed” bit is simultaneously deleted.

This bit is deleted

- after a start-up reference loop has been correctly executed

Bit 12: Incorrect target value

This bit is set

- when a transferred target value lies outside of the limit switches; also set if, for instance, the selected offsets result in a the target value outside of these limits.

This bit is deleted

- by transmitting a valid target value.

Bit 13: power was unavailable to motor

This bit is set

- if the power to the motor was insufficient for surmounting an obstruction
- if the power to the motor was insufficient for performing a start-up reference loop
- if the drive is turned more than 18° while on standby and the power to the motor was insufficient for this purpose.

This bit is deleted

- after a start-up reference loop has been correctly executed

Bit 14 / 15: Forward / reverse limit reached

This bit is set

- if the limiting value is reached during a manual run (not when reached during a positioning run)
- if a limit is modified such that the current position lies beyond it.

This bit is deleted

- by initiating a positioning run, a start-up reference loop or a manual run.

4 Sequence of positioning steps

4.1 Start-up reference loop

- The drive must be switched on before it can be controlled using PDOs.
- Execute start-up reference loop (transmit PDO with command byte 90h or SDO to index number 2024h: 90h). Drive begins run
- Wait until the drive returns the “start-up reference loop completed“ message (query PDO status bit 3 or SDO index number 2025 h: bit 3)
- Delete release if necessary (transmit PDO with command byte 0 or SDO to index number 2024h: 0).
- Deleting the release during execution will abort a reference loop.
- Other run commands are ignored during a start-up reference loop.

4.2 Positioning run

- Transfer target value (PDO with command byte 14h and target value, or target value to SDO index number 2001h): Drive begins run
- Abort run by deleting release (transmit PDO with command byte 0 or SDO to index number 2024h: 0).
- If a new target value is transferred during a positioning run, the instrument will immediately proceed to the new target. This will occur with no interruption provided the direction of rotation does not need to be altered.
- If a manual run is transmitted during a positioning run, the positioning run will be aborted (speed will be reduced to that of a slow run) and the operator may proceed with the manual run.

The following sequence of steps is also possible:

Starting conditions: Release has not been set.

- Target value transferred (no release in the command byte for PDO transfer)
- Set release: Drive begins run

4.3 Positioning run without a reference loop

The sequence corresponds to that of a positioning run with a loop; in addition to setting the release, however, bit 6 in the command byte also has to be set.

4.4 Manual run

- Transfer manual run (transmit PDO with command byte 11h resp. 12h or SDO to index number 2024h: 11h/12h.): Drive begins run
- End manual run by deleting manual run (transmit PDO with command byte 10h or SDO to index number 2024h: 10h) or by deleting release (transmit PDO with command byte 0 or SDO to index number 2024h: 0).
- Transferring a target value during a manual run will end the run and the instrument will immediately move on to the transmitted position.

5 Special features

5.1 Speed and acceleration

The start-up reference loop and manual run are performed at the starting speed (SDO no. 2013) with no acceleration phase.

Positioning runs begin at the starting speed and then accelerate to the maximum speed (SDO no. 2012). The acceleration can be modified via SDO no. 2014.

Default settings are as follows for a 1 Nm drive: starting speed = 25 rpm, maximum speed = 90 rpm, acceleration = 200 rpm/s. In other words, the drive must accelerate a total of $(90 - 25) = 65$ rpm, which at 200 rpm/s requires 0.325 seconds.

Decreasing the rate of acceleration may prove useful if a great deal of weight is being moved, as a portion of the torque will be expended to overcome inertia.

Decreasing the start and maximum speeds can also be helpful if the required torque is close to the maximum torque of the drive itself. Reducing speed causes the internal stepping motor to develop somewhat more torque.

5.2 Response of drive if it encounters an obstacle or is turned manually

If an obstacle is encountered, the positioning run will immediately be aborted if the instrument detects an error in the angle of rotation in excess of 18°. The “positioning error” bit is set and the “start-up reference loop completed” bit is deleted.

The same is true if rotated manually by more than 18°.

A start-up reference loop must be executed before beginning a new positioning run.

5.3 Calculating the absolute physical position

PSE4xxC positioning drives include an absolute measuring system. This means that the instrument can only reach positions falling within a physical measurement range of 80 rotations.

This process involves taking the transferred target values, actual values and limits obtained through referencing and any potential offset values, and converting them to the corresponding physical values.

If the referencing value is written directly, the referencing process affects all transferred values, i.e., the target value, actual value and upper and lower limit switches. When writing to the actual value, the resulting referencing value only impacts the target and actual values.

The total offset only affects the target and actual values.

physical target value = transmitted target value – referencing value + total offset

read target value = physical target value + referencing value - total offset

read actual value = physical actual value + referencing value (offset is not included in this calculation).

physical limit switch value = transmitted limit switch value – referencing value
 read limit switch value = physical limit switch value + referencing value

There are two ways of setting the reference value:

- a) By directly writing the referencing value to SDO index number 2004h
- a) Indirectly, by writing an actual value to SDO index number 2003h This makes it possible to assign any “true“ actual value to the current, physical actual value. The resulting difference is then the referencing value. This value will immediately be included in calculations for each transferred value and can also be read under SDO index number 2004h.

5.4 Spindle pitch

Index number 2010 can be used to stipulate the number of increments per rotation, a value that must be adjusted to the pitch of the spindle being driven.

The PSE4xxC works with all numerical values as if they were multiples of 1/100 mm. The value for the number of increments per rotation therefore equals the spindle pitch * 100 and may range from 10 (= a spindle pitch of 0.1 mm per rotation) to 10,000 (= a spindle pitch of 100 mm per rotation).

When setting this value it is important to note that the 1 Nm version of the PSE4xxC physically completes 2000 increments per rotation. Positioning tolerance is at least 6 increments, which means that target and actual values may not be identical for increments greater than 500 per rotation and/or that individual target values may not be accurately reached owing to error in rounding.

5.5 Braking when supply voltage fails during final stage (optional on the PSE42xC and the PSE43xC)

The PSE42xC and PSE 43xC come available with the option of a mechanical brake. In the event of a power outage, a pin is available that can be inserted into a cross bore as a means of blocking the motor shaft. The drive can be rotated a maximum of 6° in reverse before engaging the pin. Two safety precautions should be taken when removing the pin under a load: the solenoid should be operated briefly at higher power and the drive should first be rotated a few increments in the opposite direction.

The brake releases at the end of a positioning sequence.



When disassembling the PSE42xC or PSE43xC, it may be necessary to move the adjustable collar on the output shaft into a specific position. This can be accomplished by manually rotating the motor shaft; the brake, however, must first be disengaged (via the eccentric screw). Forcing the shaft to rotate without first disengaging the brake pin could destroy the drive.

5.6 Automatic reference run after the loss of power to the motor

Once power is restored following an outage, this function causes the drive to perform an automatic start-up reference loop and returns to the most recent target position. For this to work, however, the instrument must have already reached a target position. If no release has been set at the time when power is restored to the motor, this function will be performed as soon as the release is set. If the release has not yet been set and a new target value is transferred, the instrument will run through a start-up reference loop and move to the new target value.

5.7 Status history

A log is recorded of the 24 most recent status bytes. A new value is saved whenever it differs from the previous value.

At the same time, a record is also kept of the target value, actual value and command byte valid at the time when the status byte was recorded.

These values can be read via the sub index from the corresponding index number, whereby sub index 0 corresponds to the current value, sub index 1 to the second most recent, etc. When the status, target value, actual value and command byte are called up, all values corresponding to the same sub index belong together.

Bit 0 in command byte 2 (SDO# 2038) can be used to stop and restart the history recording process, which could be helpful if, for instance, positioning runs cause new data to be added while history values are still being read out.

5.8 Drag error

Index number 2032 can be used to read out the maximum difference recorded between the target and actual value whenever a second positioning run has been necessary. A maximum value is only saved when the difference is larger than the current saved value.

Writing a 0 can reset this number; any desired 16 bit value may be written, however.

6 Technical data

for the PSE 40xC

Ambient conditions	
ambient temperature	0 °C to +45 °C
storage temperature	-10 °C to +70 °C
shock resistance as stipulated in DIN IEC 68-2-27	50 g 11 ms
resistance to vibration as stipulated in DIN IEC 68-2-6	10 Hz to 55 Hz 1.5 mm 55 Hz to 1000 Hz 10 g 10 Hz to 2000 Hz 5 g
EMC standards	CE
conformity	 declaration of conformity available upon request
protection class	IP 54
Electrical data	
nominal power output	10 W (25 % OT)
power consumption	max. 35 W
supply voltage	24 VDC ± 25 %
nominal current	1.5 A
no-load current	1.0 A
positioning resolution	0.18°
positioning accuracy	0.9°
CAN protocol	CANOpen (CiA DS 301) Manufacturer Specific Profile Area (see table entitled "Index Number Assignment")
absolute value acquisition	by means of a precision potentiometer; novel method for calculating absolute position from potentiometer value.
Physical data	
positioning range	80 revolutions of the output shaft yields 160 mm run distance (max.) at a spindle pitch of 2 mm
nominal torque	1 Nm (model: 401) 1.8 Nm (model: 402) 5 Nm (model: 405)
self-holding torque (w/ current 100% OT)	1 Nm (model: 401) 1.8 Nm (model: 402) 5 Nm (model: 405)

self-holding torque (no current)	10 Ncm (model: 401) 18 Ncm (model: 402) 50 Ncm (model: 405)
nominal rated speed	80 rpm (model: 401) 45 rpm (model: 402) 17 rpm (model: 405)
torsional rigidity (angle of rotation when switching from operation w/o backlash to maximum torque)	max. 0.2°
gear backlash (no spindle offset run)	max. 0.5°
spindle offset	automatic; each new position is always approached from the same direction
output shaft	14 h 7 hollow shaft with adjustable collar
resolution	0.01 mm for a spindle pitch of 0.1 mm to 100 mm (yields 10 to 10000 increments per rotation) physical: 2000 increments per revolution (model: 401) physical: 10000 increments per revolution (model: 405)
maximum radial force	150 N
maximum axial force	80 N
dimensions (l x w x h)	135 x 56 x 86 mm
weight	1,300 g

for the PSE 41xC

Ambient conditions	
ambient temperature	0 °C to +45 °C
storage temperature	-10 °C to +70 °C
shock resistance as stipulated in DIN IEC 68-2-27	50 g 11 ms
resistance to vibration as stipulated in DIN IEC 68-2-6	10 Hz to 55 Hz 1.5 mm 55 Hz to 1000 Hz 10 g 10 Hz to 2000 Hz 5 g
EMC standards	CE
conformity	 declaration of conformity available upon request
protection class	IP 54
Electrical data	
nominal power output	10 W (25 % OT)
power consumption	max. 35 W
supply voltage	24 VDC ± 25 %
nominal current	1.5 A
no-load current	1.0 A
positioning resolution	0.18°
positioning accuracy	0.9°
CAN protocol	CANOpen (CiA DS 301) Manufacturer Specific Profile Area (see table entitled "Index Number Assignment")
absolute value acquisition	by means of a precision potentiometer; novel method for calculating absolute position from potentiometer value.
Physical data	
positioning range	80 revolutions of the output shaft yields 160 mm run distance (max.) at a spindle pitch of 2 mm
nominal torque	1 Nm (model: 411) 5 Nm (model: 415)
self-holding torque (w/ current 100 % OT)	1 Nm (model: 411) 5 Nm (model: 415)
self-holding torque (no current)	10 Ncm (model: 411) 50 Ncm (model: 415)
nominal rated speed	90 rpm (model: 411) 17 rpm (model: 415)
torsional rigidity (angle of rotation when switching from operation w/o backlash to maximum torque)	max. 0.2°
gear backlash (no spindle offset run)	max. 0.5°
spindle offset	automatic; each new position is always approached from the same direction
output shaft	14 h 7 hollow shaft with adjustable collar

resolution	0.01 mm for a spindle pitch of 0.1 mm to 100 mm (yields 10 to 10000 increments per rotation) physical: 2000 increments per revolution (model: 411) physical: 10000 increments per revolution (model: 415)
maximum radial force	150 N
maximum axial force	80 N
dimensions (l x w x h)	70 x 56 x 145 mm
weight	1,000 g

for the PSE 42xC

Ambient conditions	
ambient temperature	0 °C to +45 °C
storage temperature	-10 °C to +70 °C
shock resistance as stipulated in DIN IEC 68-2-27	50 g 11 ms
resistance to vibration as stipulated in DIN IEC 68-2-6	10 Hz to 55 Hz 1.5 mm 55 Hz to 1000 Hz 10 g 10 Hz to 2000 Hz 5 g
EMC standards	CE
conformity	 declaration of conformity available upon request
protection class	IP 54
Electrical data	
nominal power output	24 W (25 % OT)
power consumption	max. 60 W
supply voltage	24 VDC ± 25 %
nominal current	3.0 A
no-load current	1.5 A
positioning resolution	0.18°
positioning accuracy	0.9°
CAN protocol	CANOpen (CiA DS 301) Manufacturer Specific Profile Area (see table entitled "Index Number Assignment")
absolute value acquisition	by means of a precision potentiometer; novel method for calculating absolute position from potentiometer value.
Physical data	
positioning range	80 revolutions of the output shaft yields 160 mm run distance (max.) at a spindle pitch of 2 mm
nominal torque	3 Nm (model: 423) 10 Nm (model: 4210) 25 Nm (model: 4225)
self-holding torque (w/ current 100 % OT)	3 Nm (model: 423) 10 Nm (model: 4210) 25 Nm (model: 4225)
self-holding torque (no current)	30 Ncm (model: 423) 100 Ncm (model: 4210) 250 Ncm (model: 4225)
nominal rated speed	75 rpm (model: 423) 22 rpm (model: 4210) 9 rpm (model: 4225)
torsional rigidity (angle of rotation when switching from operation w/o backlash to maximum torque)	max. 0.2°
gear backlash (no spindle offset run)	max. 0.5°

spindle offset	automatic; each new position is always approached from the same direction
output shaft	14 h 7 hollow shaft with adjustable collar (model 423) 14 h 7 hollow shaft with adjustable collar and feather key (models 4210, 4225)
resolution	0.01 mm for a spindle pitch of 0.1 mm to 100 mm (yields 10 to 10000 increments per rotation) physical: 2000 increments per revolution (model: 423) physical: 8200 increments per revolution (model: 4210) physical: 2000 increments per revolution (model: 4225)
maximum radial force	150 N
maximum axial force	80 N
dimensions (l x w x h)	135 x 56 x 86 mm
weight	1,700 g (model: 423) 1,900 g (model: 4210/4225)
optional	holding brake

for the PSE 43xC

Ambient conditions	
ambient temperature	0 °C to +45 °C
storage temperature	-10 °C to +70 °C
shock resistance as stipulated in DIN IEC 68-2-27	50 g 11 ms
resistance to vibration as stipulated in DIN IEC 68-2-6	10 Hz to 55 Hz 1.5 mm 55 Hz to 1000 Hz 10 g 10 Hz to 2000 Hz 5 g
EMC standards	CE
conformity	 declaration of conformity available upon request
protection class	IP 54
Electrical data	
nominal power output	24 W (25 % OT)
power consumption	max. 60 W
supply voltage	24 VDC ± 25 %
nominal current	3.0 A
no-load current	1.5 A
positioning resolution	0.18°
positioning accuracy	0.9°
CAN protocol	CANOpen (CiA DS 301) Manufacturer Specific Profile Area (see table entitled "Index Number Assignment")
absolute value acquisition	by means of a precision potentiometer; novel method for calculating absolute position from potentiometer value.
Physical data	
positioning range	80 revolutions of the output shaft yields 160 mm run distance (max.) at a spindle pitch of 2 mm
nominal torque	3 Nm (model: 433) 10 Nm (model: 4310) 25 Nm (model: 4325)
self-holding torque (w/ current 100 % OT)	3 Nm (model: 433) 10 Nm (model: 4310) 25 Nm (model: 4325)
self-holding torque (no current)	30 Ncm (model: 433) 100 Ncm (model: 4310) 250 Ncm (model: 4325)
nominal rated speed	75 rpm (model: 433) 22 rpm (model: 4310) 9 rpm (model: 4325)
torsional rigidity (angle of rotation when switching from operation w/o backlash to maximum torque)	max. 0.2°
gear backlash (no spindle offset run)	max. 0.5°

spindle offset	automatic; each new position is always approached from the same direction
output shaft	14 h 7 hollow shaft with adjustable collar (model 433) 14 h 7 hollow shaft with adjustable collar and feather key (models 4310 and 4325)
resolution	0.01 mm for a spindle pitch of 0.1 mm to 100 mm (yields 10 to 10000 increments per rotation) physical: 2000 increments per revolution (model: 433) physical: 8200 increments per revolution (model: 4310) physical: 2000 increments per revolution (model: 4325)
maximum radial force	150 N
maximum axial force	80 N
dimensions (l x w x h)	85 x 60 x 160 mm
weight	1,700 g (model: 433) 1,900 g (model: 4310/4325)
optional	holding brake

7 Dimension drawings

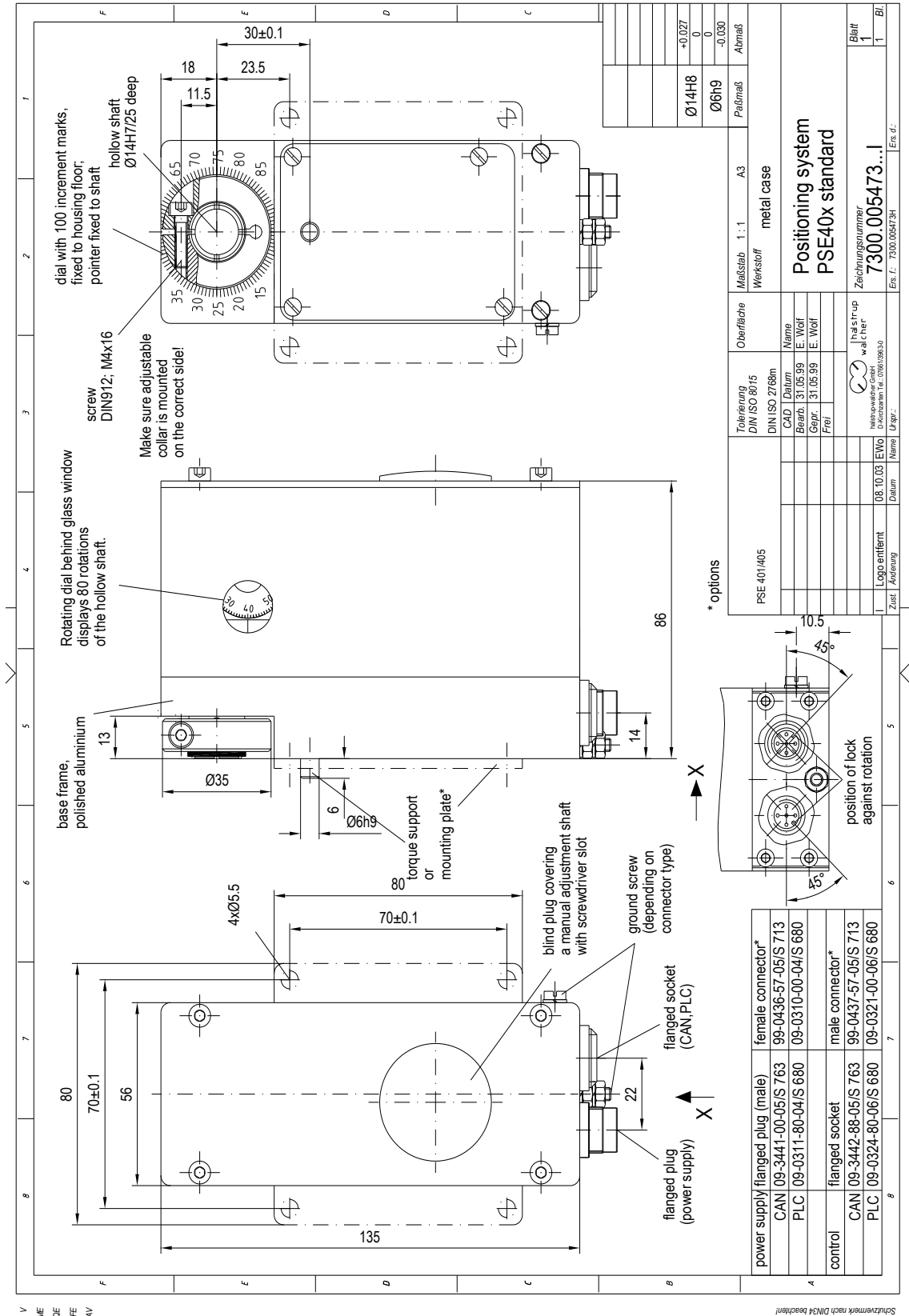

Schutzvermerk nach DIN34 beachten!

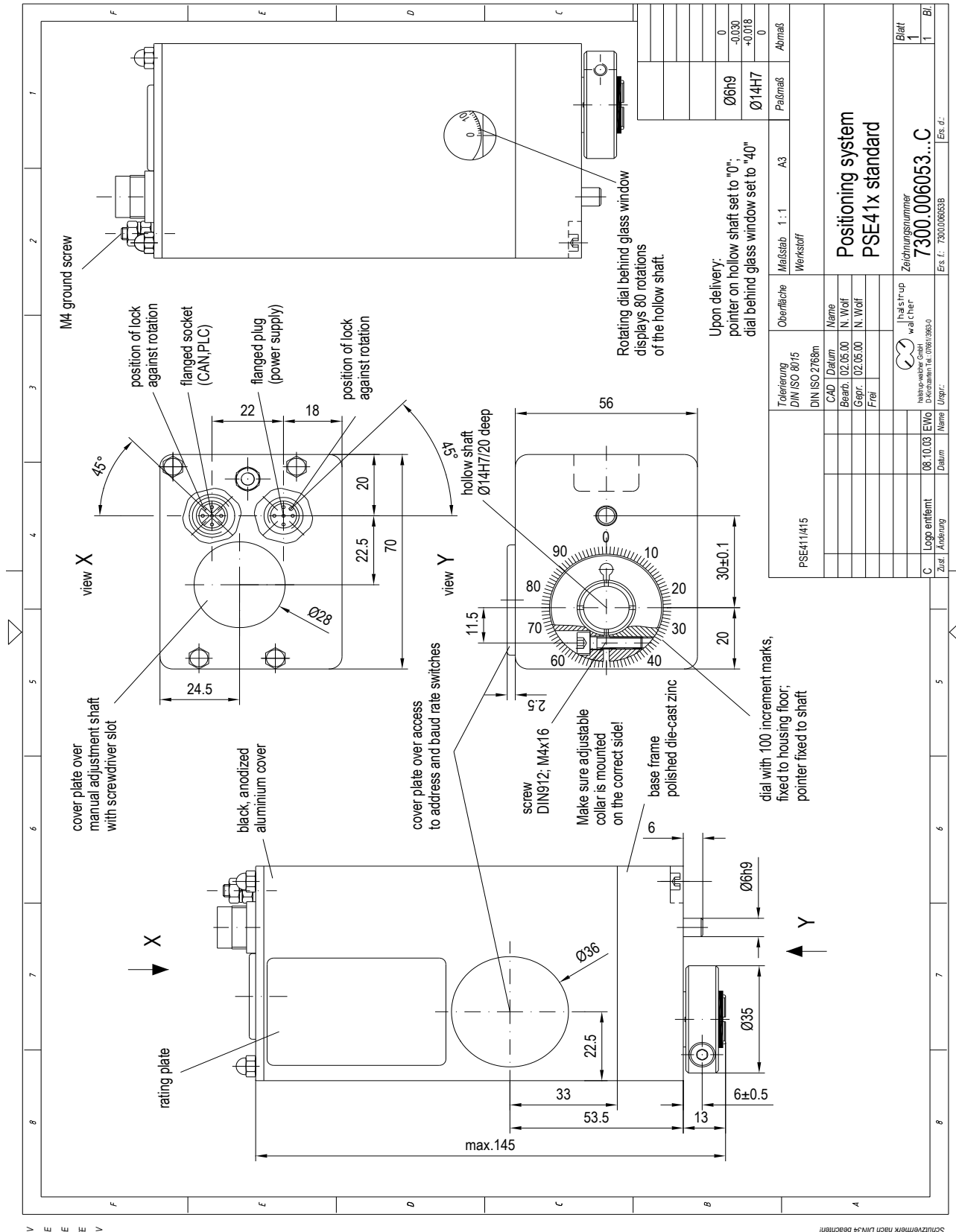

Tolerierung DIN ISO 8015 DIN ISO 2768m		Oberfläche Arbeitsstoff		Maßstab 1:1 A3	
CAD	Datum	Name	Abmaß		
Bearb.	02.05.00	N. Wolf	Ø6h9	0	
Gedr.	02.05.00	N. Wolf	Ø14H7	+0.018	
Frei				0	
PSE411415			Positioning system PSE41x standard		
Logo entleert	08.10.03	EWO	Zeichnungsnummer 7300.006053...C		
Zust. Änderung			Ers. f.: 7300.006053B		
			Ers. d.:		
			Blatt 1 1		

SCHUTZMERK NACH DIN EN 60950

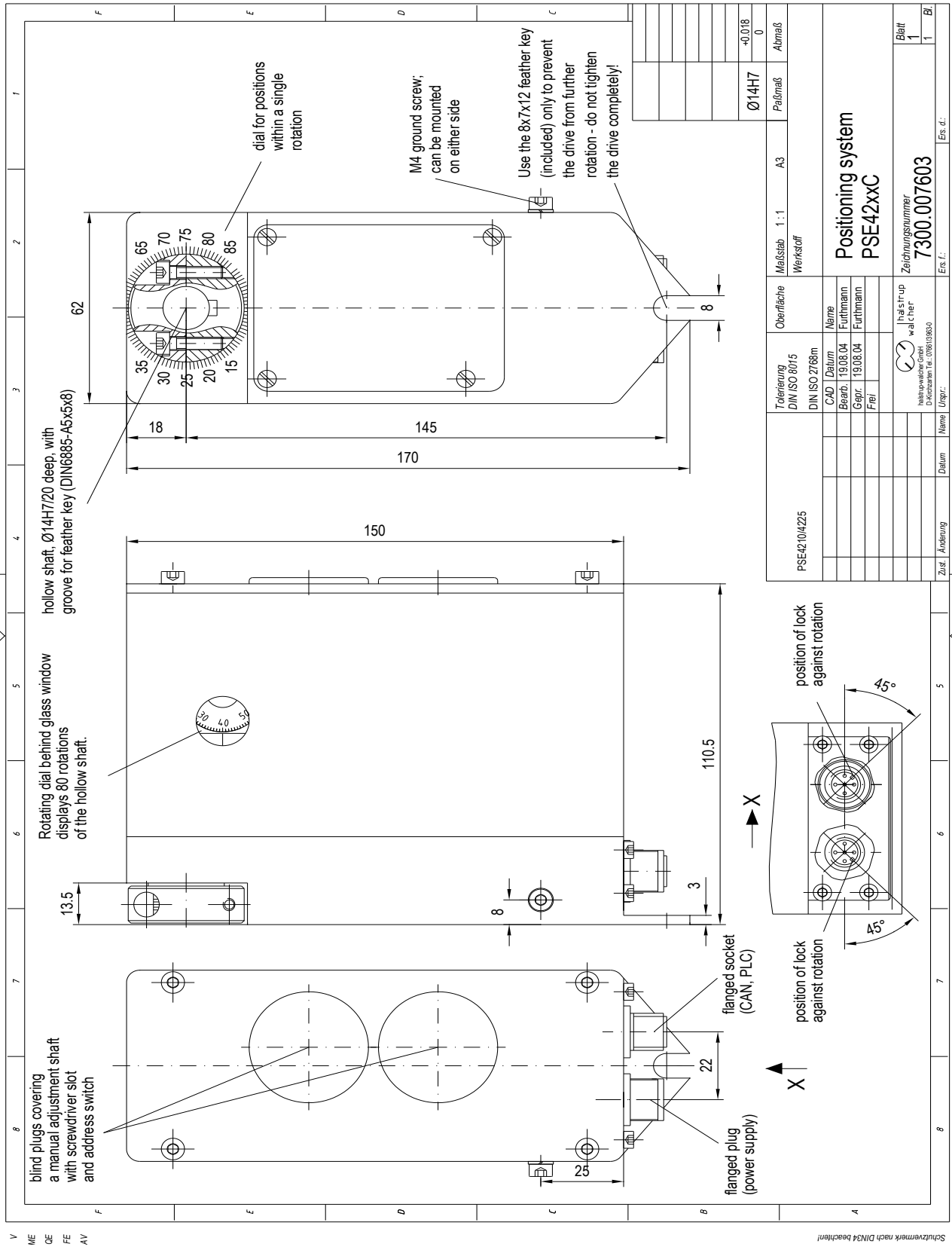

V
ME
OE
FE
AV

Schutzmerk nach DIN3 beachten!

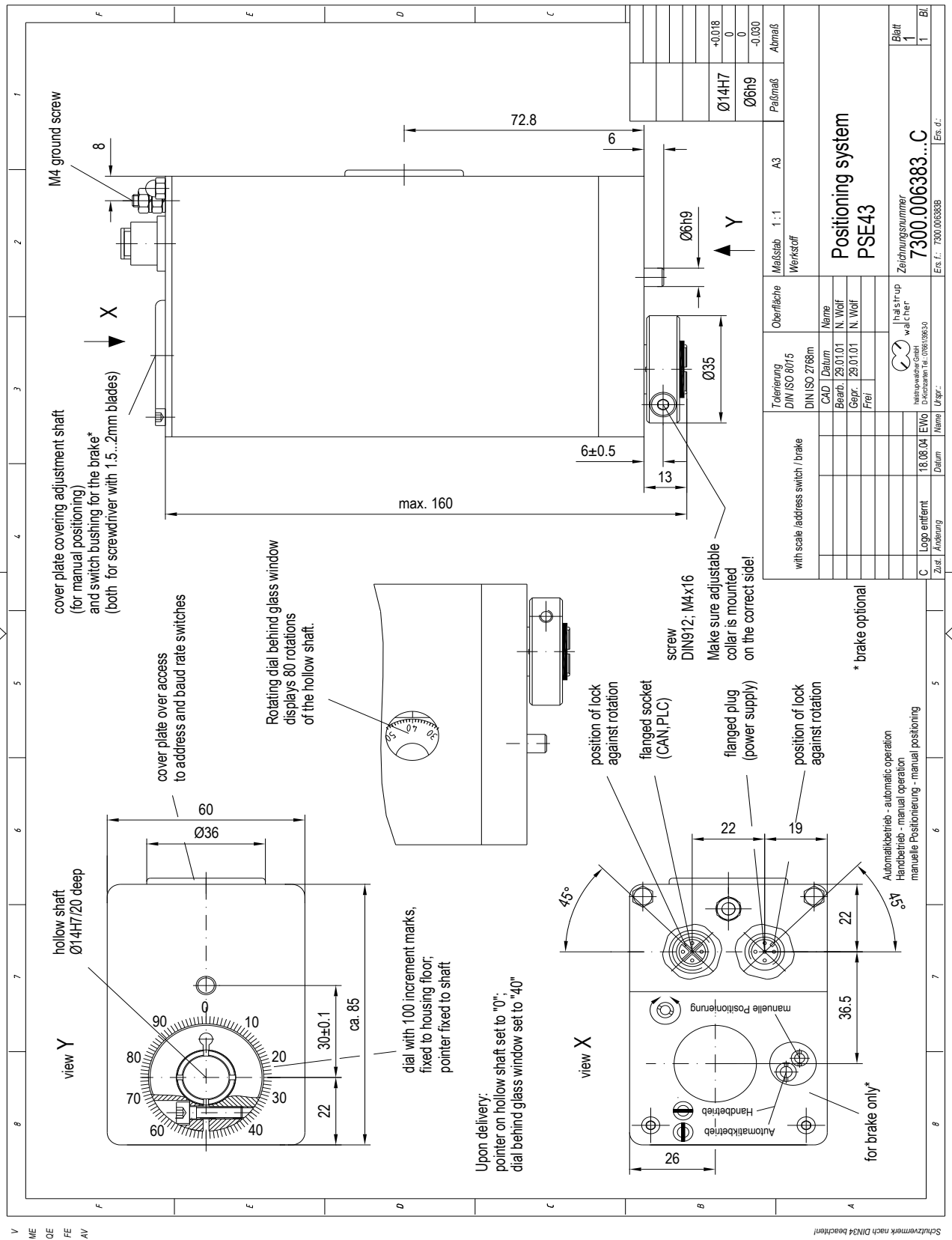

7100.003644B_PSE4xxC_eng.doc 22.08.14 ka/Ze