

# Instruction Manual REG 21 Pressure Regulator



halstrup-walcher GmbH

Stegener Straße 10  
D-79199 Kirchzarten  
Germany

Phone: +49 (0) 76 61/39 63-0  
Fax: +49 (0) 76 61/39 63-99

E-Mail: [info@halstrup-walcher.com](mailto:info@halstrup-walcher.com)  
Internet: [www.halstrup-walcher.com](http://www.halstrup-walcher.com)

## Table of Contents

1	Safety precautions .....	4
1.1	Appropriate use.....	4
1.2	Shipping, assembly, electrical connections and start-up.....	4
1.3	Troubleshooting, maintenance, repairs, disposal.....	4
1.4	Symbols .....	5
2	Instrument description .....	6
3	Start-up.....	6
3.1	Features.....	6
3.1.1	Inputs and outputs.....	6
3.1.2	Display elements.....	7
3.1.3	Keypad.....	7
3.1.4	Menu tree.....	8
3.2	User functions.....	9
3.3	Device parameters.....	10
3.4	Switching behaviour.....	11
3.5	Zero-point calibration .....	12
3.5.1	Sequence of zero-point calibration steps.....	12
3.6	Overload protection .....	12
4	Identification.....	13
4.1	Included in shipment.....	13
4.2	Product labelling .....	13
4.3	Models.....	13
5	Electrical connections and installation .....	14
5.1	Installation .....	14
5.2	Instrument connections.....	14
5.2.1	Pressure ports.....	14
5.2.2	Electrical connections.....	15
5.2.3	Option light emitting diodes (LED).....	15
6	Start-up .....	16
6.1	Setting parameters .....	17
6.1.1	Overview of parameter setting functions and parameters.....	17
6.1.2	Launching a parameter setting function.....	18
6.2	Setting parameters .....	18
6.2.1	Notes on setting switching value parameters. ....	20
7	Troubleshooting .....	21
8	Technical data.....	22
9	Dimension drawings.....	24
10	Certificate of Conformity .....	25

## Purpose of instruction manual

This instruction manual describes the features of the REG 21 pressure regulator and provides guidelines for its use.

Improper use of this instrument or failure to follow these instructions may cause injury or equipment damage. All individuals responsible for operating this instrument must therefore be properly trained and aware of the hazards, and must carefully follow these operating instructions and the safety precautions detailed within. **Contact the manufacturer if you do not understand any part of this instruction manual.**

Handle this manual with care:

- It must be readily available throughout the lifecycle of the instrument.
- It must be provided to any individuals who assume responsibility for operating the instrument at a later date.
- It must include any supplementary materials provided by the manufacturer.

The manufacturer reserves the right to continue developing this instrument model without documenting such development in each individual case. The manufacturer will be happy to determine whether this manual is up-to-date.

## Conformity

This instrument corresponds to the state of the art and meets all legal requirements set forth in EC directives as evidenced by the CE label.



© 2002, 2015, 2018

The manufacturer owns the copyright to this instruction manual. This manual contains data, instructions and drawings pertaining to the features and usage of this instrument; copying this manual in part or in full or distributing it to third parties is prohibited.

# 1 Safety precautions

## 1.1 Appropriate use

The REG 21 pressure regulator is designed for measuring, displaying, monitoring and regulating positive and negative overpressures and differential pressures of non-aggressive, gaseous media.

Always observe the operating requirements—particularly the permissible supply voltage—indicated on the rating plate and in the “Technical data” section of this manual.

The instrument may only be handled as indicated in this manual. Modifications to the instrument are prohibited. The manufacturer is not liable for damages caused by improper use or failure to follow these instructions. Violations of this type render all warranty claims null and void.

## 1.2 Shipping, assembly, electrical connections and start-up

Do not close the pressure input ports when shipping, as changes in barometric pressure could damage instruments with low measuring ranges.

Only technical personnel who are appropriately trained and authorized by the operator of the facility may assemble the instrument and set up its electrical connections.

The instrument may only be operated by appropriately trained individuals who have been authorized by the operator of the facility.

Pressurized air or breath is not to be used for performance tests, as this could damage instruments with low measurement ranges.

Measurement errors may occur if the instrument is not kept protected from sunlight.

Specific safety precautions are given in individual sections of this manual.

## 1.3 Troubleshooting, maintenance, repairs, disposal

The individual responsible for the electrical connections must be notified immediately if the instrument is damaged or if errors occur.

This individual must take the instrument out of service until the error has been corrected and ensure that it cannot be used unintentionally.

### **Always unplug the power cord before opening the instrument!**

This instrument requires no maintenance.

Only the manufacturer may perform repairs that require the housing to be opened.

The electronic components of the instrument contain environmentally hazardous materials and materials that can be reused. For this reason the instrument must be recycled in accordance with the environmental guidelines of the jurisdiction in question once it has been taken permanently out of service.

#### 1.4 Symbols

The symbols given below are used throughout this manual to indicate instances when improper operation could result in the following hazards:



**WARNING!** This warns you of a potential hazard that could lead to bodily injury up to and including death if the corresponding instructions are not followed.



**WARNING:** This warns you of a potential hazard that could lead to significant property damage if corresponding instructions are not followed.



**INFORMATION:** This indicates that the corresponding information is important for operating the instrument properly.

## 2 Instrument description

The REG 21 pressure regulator measures differential pressures between its two pressure ports, which lead to two chambers of a pressure measurement capsule. Pressure is measured via a beryllium bronze membrane spring, which is displaced by the pressure difference between the two chambers. Inductive displacement transducers measure membrane deflection without contacting the membrane. The instrument has no frictional parts or parts subject to mechanical wear, and performs the following tasks:

- Displays the measured value
- Provides the voltage (current is also an option) proportional to the measured value.
- Its two switching outputs make it suitable for use as either a two-point or a three-point controller

The following are some additional features worth highlighting:

- Overload protection
- Adjustable switching hysteresis
- High level of sensitivity
- High level of accuracy and long-term stability
- Automatic zero-point correction
- Low temperature dependence

## 3 Start-up

### 3.1 Features

#### 3.1.1 Inputs and outputs

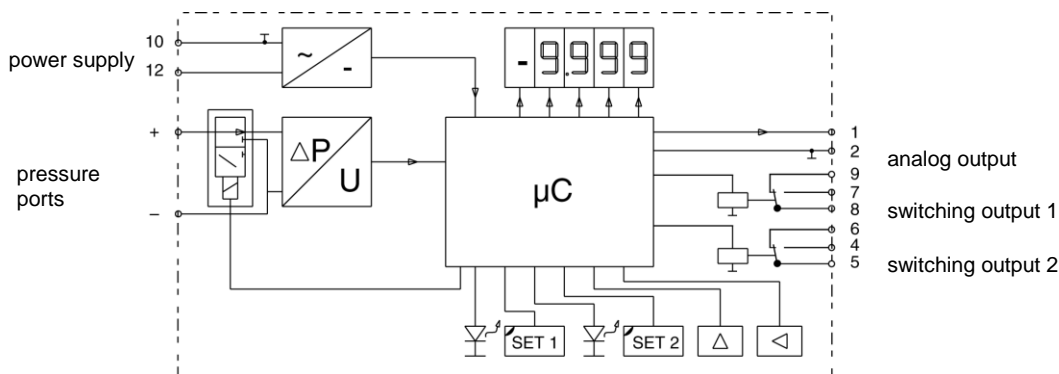

Fig. 1: basic circuit diagram

**Power supply:** Depending on the model, the power is supplied as either 230 V-AC, 115 V-AC, 24 V-AC or 24 V-DC. The details of the supply voltage are given on the rating plate.

**Pressure ports:** (-) port: reference pressure; (+) port: pressure to be measured. The measurement range is given on the rating plate.

**Analogue output:** The instrument produces a voltage output proportional to the measured pressure. Output is in the range of 0...10 V (ranges of -5...+5 V, 4...20 mA or 0...20 mA are optional). The spread of the analogue output values is proportional to the measurement range. The type of analogue output is indicated on the rating plate.

**Switching outputs 1 and 2:** The instrument comes equipped with 2 relay outputs (2 transistor outputs are also an option). The type of switching output is indicated on the rating plate. Switching outputs are triggered when values exceed and/or fall below switch-on and switch-off values. See section 3.4 for a more detailed description of switching behaviour. The instrument utilizes changeover relays and bipolar NPN transistors, making it possible to create either open-collector or open-emitter circuits.

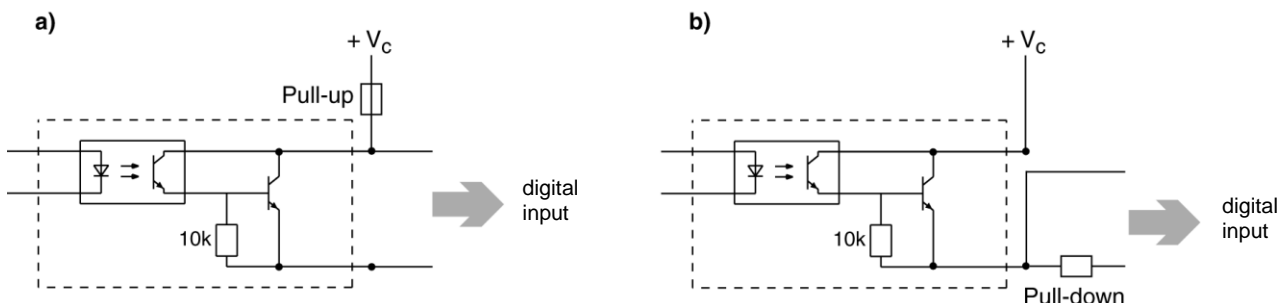

Fig. 2 Transistor output (optional) a) open-collector circuit b) open-emitter circuit

### 3.1.2 Display elements

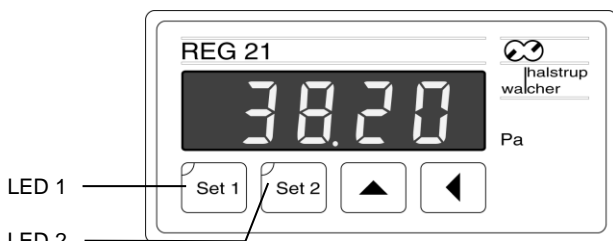

Fig. 3 Front view of the instrument

**Display:** The display shows the measured differential pressure or overpressure in the units indicated on the housing next to the display. Positive values are displayed as is; negative values are indicated by a preceding minus sign.

**LED 1:** LED 1 shows the status of switching output 1 and is illuminated whenever the switch-on value exceeds or falls below that set for switching output 1 (see fig. 5).

**LED 2:** LED 2 shows the status of switching output 2 in a way analogous to that of output 1.

### 3.1.3 Keypad

The instrument is set by means of 4 keys, whose functions are described in the following:

	<p><b>Set key:</b></p> <ul style="list-style-type: none"> <li>• Call up and exit parameter setting and display functions</li> <li>• Save parameters</li> </ul>
	<p><b>Enter key:</b></p> <ul style="list-style-type: none"> <li>• Begin and end settings</li> <li>• Select decimal places and +/- sign</li> </ul>
	<p><b>Select key:</b></p> <ul style="list-style-type: none"> <li>• Select values or parameters</li> <li>• Set numerical values</li> </ul>

Table 1

### 3.1.4 Menu tree

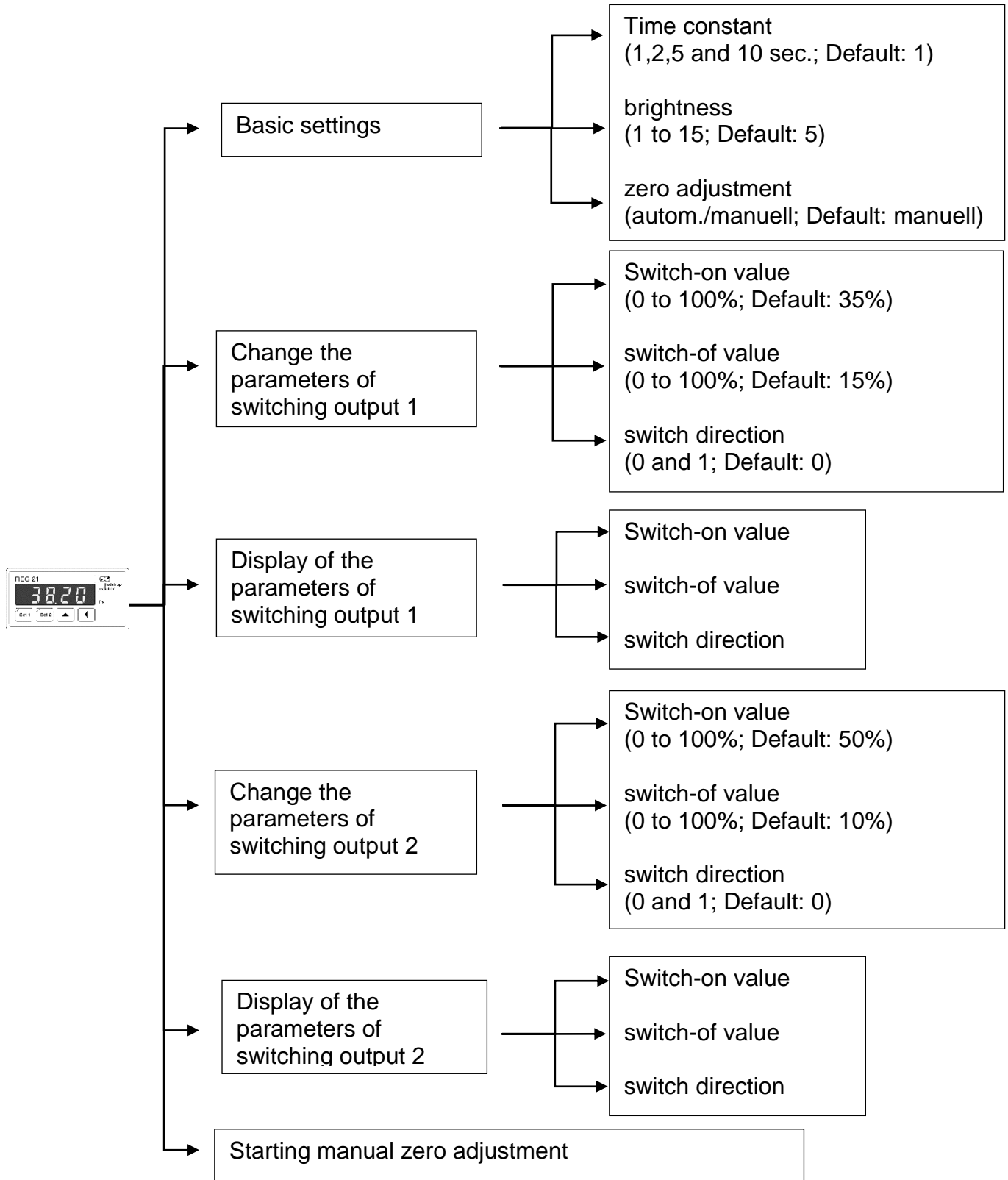







### 3.2 User functions

User functions include setting device parameters, displaying switching output parameters and manually performing a zero-point calibration.

Users call up these functions by pressing the **set keys**; the specific function called up depends on whether the keys are pressed individually or in combination, and for how long they are pressed. Moving decimal points indicate that the instrument is no longer displaying measured values (see fig. 7).

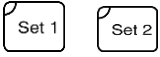
Function		
parameter setting	Key sequence	Parameter
basic settings	 press both and hold for <2 s*	Time constant Brightness Zero adjustment (see section 6.1)
setting parameters for switching output 1	 hold for >2 s**	Switch-on value Switch-of value
setting parameters for switching output 2	 hold for >2 s**	Switch direction (see section 6.1)
display functions	Key sequence	Values shown
displaying parameters for switching output 1	 hold for <2 s*	Switch-on value Switch-of value Switch direction
displaying parameters for switching output 2	 hold for <2 s*	(Values are displayed one after the other. The display then returns to the measured value; see section 3.4)
Other functions	Key sequence	Process flow
Start manual zero-point calibration	 depress simultaneously and hold for >2 s**	The zero-point calibration is performed automatically. The display then returns to the measured value.
* hold for <2 s: depress the key(s) until the decimal points on the measured value display begin to move (see fig. 7 (2)) ** hold for > 2 s: depress the key(s) until the "PPP" release code appears (see fig. 7 (3)).		

**Table 2 User functions for the REG 21 pressure regulator**

### 3.3 Device parameters

Several parameters are available for adapting instrument operation to a number of different applications. Section 6.1 describes how to set parameters; table 3 provides an overview of available parameters.

Parameter	Description
<b>basic settings</b>	
time constant	the amount of time required for the display, analogue output and (if the corresponding parameters are set) switching outputs to respond to changes in pressure
brightness	display brightness
zero-point calibration	automatic or manual zero-point calibration options
<b>relay output 1</b>	
switch-on value	pressure threshold value that activates the switching output, see section 3.4
switch-off value	pressure threshold value that disables the switching output, see section 3.4
switch direction	parameter for selecting one of the two possible directions between the two relay/transistor output states, see section 3.4
<b>switching output 2 (analogous to switching output 1)</b>	
switch-on value	see above
switch-off value	see above
switch direction	see above

**Table 3 parameters for the REG 21 pressure regulator**

### 3.4 Switching behaviour

The behaviour of the switching outputs is determined by the settings for the switch-on, switch-off and switch direction parameters.

Both switching outputs can each be used individually as two-point controllers or in combination as three-point controllers. The following diagrams illustrate this feature and define the behaviour of the switching outputs.

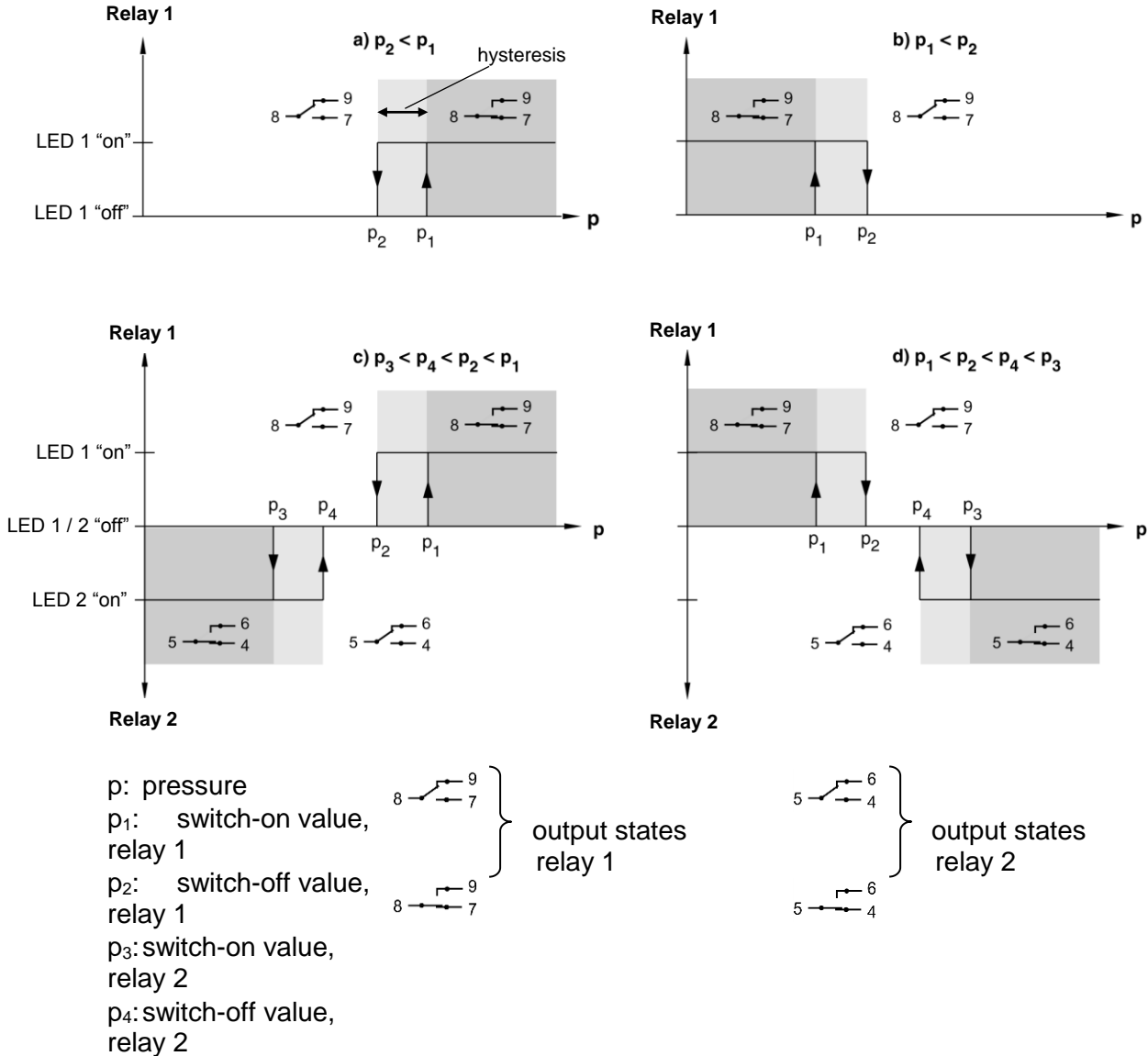

The numbers indicate the terminal assignment (see fig. 6)

**Fig. 4 Behaviour of switching outputs; switch direction = "0"** a), b) relay 1 as a two-point controller c), d) relay 1 and 2 in combination as a three-point controller

The following are the equivalents for transistor outputs:

↔ "blocking transistor"

↔ "conducting transistor"

If the "switch direction" parameter is set to "1," the switching output behaviour will be reversed. The following are transposed in fig. 4:

↔ "blocking transistor"

↔ "conducting transistor"

### 3.5 Zero-point calibration

The instrument's zero point can be calibrated either automatically or manually; the type of calibration is determined by the "zero-point calibration" parameter setting (see section 6.1)

- If this parameter is set to "automatic zero-point calibration," the zero point will be calibrated automatically as soon as the instrument is switched on and then again 15 minutes later. A calibration will then be performed every 60 min.
- If this parameter is set to "manual zero-point calibration," the automatic zero-point calibration feature is suppressed.

The zero point will be calibrated any time the manual zero-point calibration feature is triggered (see table 2)—even if the zero-point calibration parameter is set to automatic.



**The zero point can only be calibrated manually on instrument models with no bypass valve (see section 4.3).**

#### 3.5.1 Sequence of zero-point calibration steps

When calibrating the zero point, a valve briefly closes both pressure ports for six seconds ( $\Delta p = 0$ ).

The instrument then checks for 3 seconds to determine whether the deviation from zero is within the permissible range. If not, e.g., if the pressure measurement capsule has been overloaded and damaged, the instrument returns error message E004.

If the deviation is within the permissible range, the zero point will be measured for an additional 3 seconds in order to obtain a mean value.

After opening the bypass valve, the instrument returns to measurement mode. Each measured value is then corrected by the stored zero-point deviation value (offset value).



**Pressure cannot be monitored during zero-point calibration; instead, the most recently measured value prior to calibration is read out and displayed.**

### 3.6 Overload protection



**Only available for instrument models with a bypass valve (see section 4.3)**

This valve, which is bypassed during the zero-point calibration process, performs an additional function: it briefly closes the pressure input ports as soon as the pressure (measured differential pressure value) is 50% higher than the nominal pressure (final value of the measurement range).

## 4 Identification

### 4.1 Included in shipment

- The instrument model ordered
- This instruction manual

### 4.2 Product labelling

The rating plate provides the following information:

- measurement range
- type of analogue output
- precision class
- supply voltage
- number and type of switching outputs
- product number
- the CE emblem

The second label indicates the pin assignment.

### 4.3 Models

The following instrument models are available:

measurement ranges:	±0 ... 50 Pa to ±0 ... 100 kPa			
analog outputs:	0 ... 10 V	-5 ... 5 V	0 ... 20 mA	4 ... 20 mA
power supply:	230 V-AC	115 V-AC	24 V-AC	24 V-DC
switching outputs:	2 relays		2 transistors	
zero-point calibration and overload protection	bypass valve (automatic zero-point calibration and overload protection available)		no bypass valve (automatic zero-point calibration and overload protection <b>not</b> available)	

**Table 4**

## 5 Electrical connections and installation

### 5.1 Installation

- ⇒ The instrument should be installed in a control panel with a rectangular recess (92 + 0.8 mm x 45 + 0.6 mm) using the installation parts included in the shipment.

### 5.2 Instrument connections

#### 5.2.1 Pressure ports

- ⇒ Connect tubing ( $\varnothing$  6,5 mm) for reference pressure at the (-) port.
- ⇒ Connect tubing ( $\varnothing$  6,5 mm) for measured pressure at the (+) port.

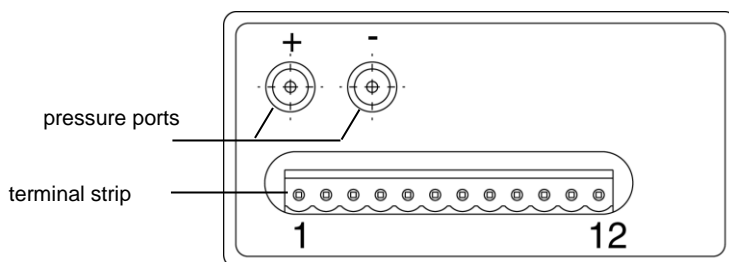

Fig. 5 rear view of the REG 21 pressure regulator

### 5.2.2 Electrical connections



**WARNING!** The instrument is available in a number of different models. The model is identifiable by the features described in section 4.2 and indicated on the rating plate and on the second housing label. The model must be identified before making any electrical connections.



**WARNING! RISK OF ELECTRICAL SHOCK!** Do not attempt to make any electrical connections unless the cables attached to both switching outputs are at zero potential and the power supply has been switched off.



The instrument operates with a floating ground

⇒ Set up the electrical connections as indicated on the housing label or in fig. 6.

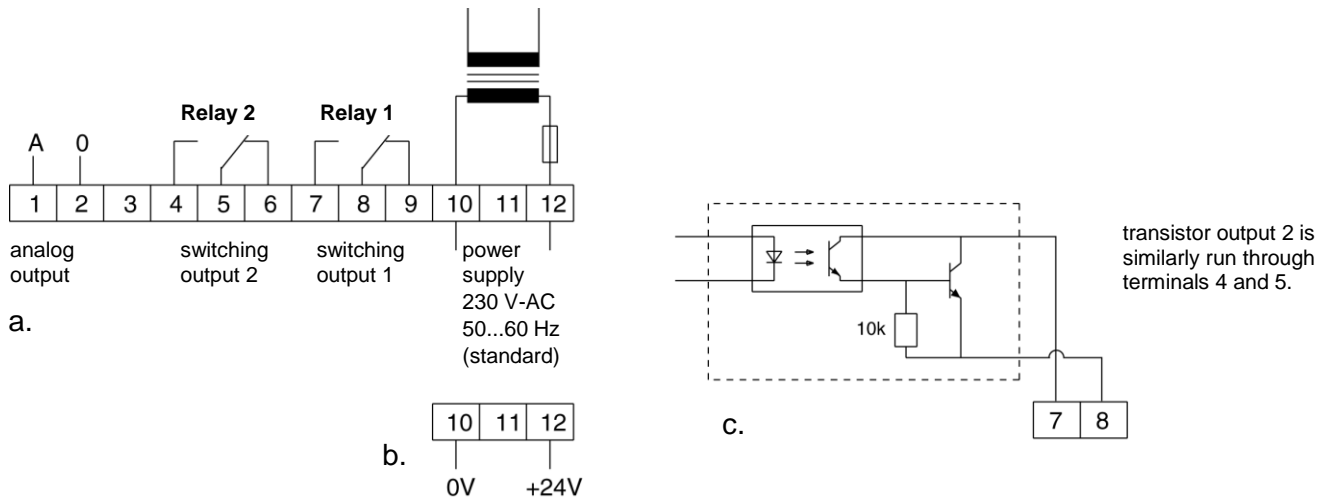
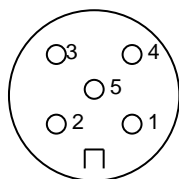

Fig. 6 Pin assignment for terminal strip (from fig. 5):

- a. standard unit with 24 V / 115 V-AC options;
- b. 24 V-DC option;
- c. with optically coupled transistor output (output 1)

### 5.2.3 Option light emitting diodes (LED)

Pin assignment for terminal for LED



- 1 – Cathode(-) LED A
- 2 – Cathode(-) LED B
- 3 – Cathode(-) LED C
- 4 – not connected
- 5 – common anode(+)

## 6 Start-up

Switch on unit by connecting the power supply.

The instrument will automatically execute the following sequence of steps:

- The unit will run a check, causing all display segments to light up for 2 seconds. Both outputs are switched off and the corresponding LED goes dark.
- Basic settings are automatically checked for plausibility. If they fail, the instrument generates an error message (see section 7).
- The zero point is then calibrated if this function is part of the instrument's program. If zero point lies outside of the permissible range, the instrument generates an error message (see section 7).
- Transition to monitoring and display mode:
  - Displays current pressure
  - Reads out an analogue value proportional to the pressure
  - Controls switching outputs in keeping with set parameters
  - Displays output states with LED



Setting instrument parameters as detailed in section 6.1.

After its parameters have been set, the instrument is in monitoring and display mode, in which it can perform its measurement, control and monitoring functions.



## 6.1 Setting parameters



- If parameter mode is not released within 30 s of calling up a parameter setting function, the instrument returns to monitoring and display mode.
  - Press either of the set keys ( or ) to exit parameter mode while setting parameters (prior to concluding the session by depressing the enter key ).
- The instrument will return to monitoring and display mode if no parameters are entered within 30 s of entering parameter mode.









The original parameters will not be affected in either of these cases.

While in parameter mode, the instrument will continue to monitor pressure and control the switching outputs and analogue outputs.

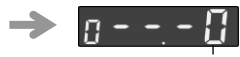

**WARNING!** Hysteresis is critical for all switching values (see fig. 5) in order to prevent the relay from “fluttering” or the transistors from periodically switching on/off.

### 6.1.1 Overview of parameter setting functions and parameters



Parameter	Parameter ID	Options	Default values
<b>basic settings:</b>		   depress both keys; hold for <2 s*	function
time constant	 parameter	n 1, n 2, n 5, n 10 F 1, F 2, F 5, F 10 1, 2, 5, 10: time constants in s n: time constants apply to display, analogue output and switching outputs F: time constants apply to display and analogue output; switching outputs will be triggered 20 ms later	F 1
brightness		unitless value of 1...15	5
zero-point calibration		AU: automatic zero-point calibration nor: manual zero-point calibration	nor
<b>switching output 1</b>		 hold for >2 s** 	
switch-on value		entire measurement range	35 %

switch-off value	1 - - - 1	entire measurement range	25 %
switch direction	2 - - - 1	0, 1	0
<b>switching output 2:</b>		Set 2 hold for >2 s** →	0 - - - 2
switch-on value		entire measurement range	50 %
switch-off value	1 - - - 2	entire measurement range	10 %
switch direction	2 - - - 2	0, 1	0
<p>* hold for &lt;2 s: depress the key(s) until the decimal points on the measured value display begin to move (see fig. 7 (2))</p> <p>** hold for &gt; 2 s: depress the key(s) until the “PPP” release code appears (see fig. 7 (3)).</p>			

**Table 5**

**6.1.2 Launching a parameter setting function**

(see fig. 7)

- ⇒ Call up the desired parameter function as indicated in table 5 (1).
- ⇒ Enter parameter mode by pressing the following keys in sequence: , ,  (4).  
“Function and parameter ID” will appear (5).

**Example: Calling up the “basic settings” parameter function**

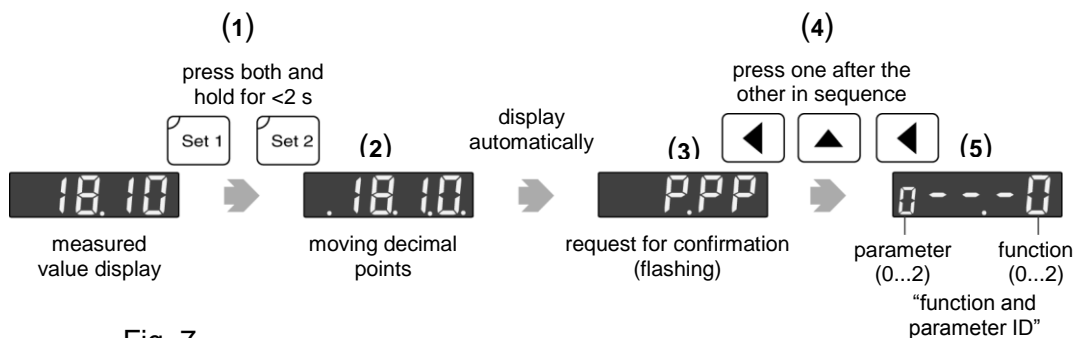







Fig. 7

**6.2 Setting parameters**

Use the following procedure (starting from “function and parameter ID”) to set parameters (see fig. 8).

- ⇒ Press  to select the parameter to be changed (0).
- ⇒ Press the enter key  to open the parameter settings dialog (1).

- The display shows the value currently set for the parameter (2).
- ⇒ Press  (multiple times) to select the desired value (3).
  - ⇒ Press the enter key  to confirm the selected value (4).
  - ⇒ Press one of the set keys ( or ) to save the value (5).
- The instrument will display the function and parameter ID for the next parameter (6).
- ⇒ Set the remaining parameters in the same way (7).

Example: Setting the “basic settings” parameters

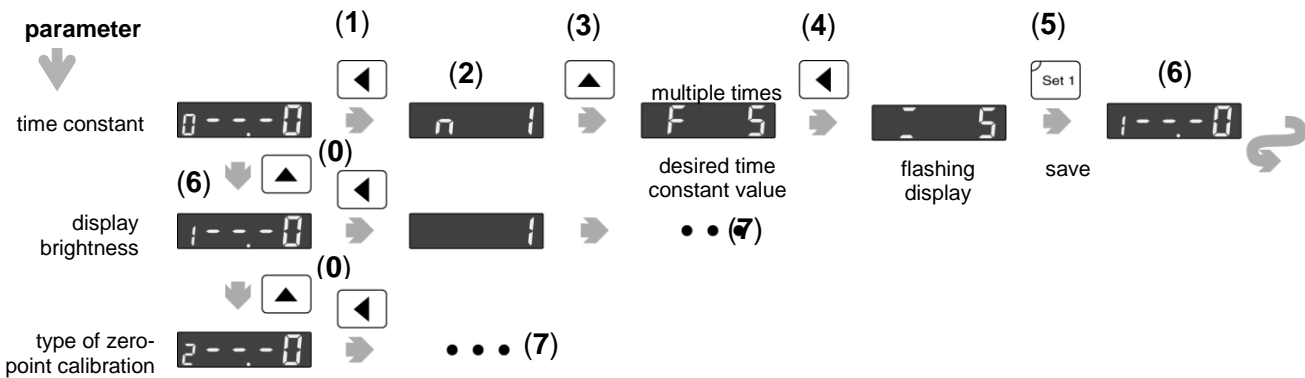



Fig. 8

### 6.2.1 Notes on setting switching value parameters.

Switching values can be entered as decimal figures; each place must be set individually, proceeding as follows and beginning with the “function and parameter code” (see fig. 9):

Press the enter key  to open the parameter settings dialog (1).



The current value is displayed; the numbers of the final decimal place will be flashing (2).

Continue as follows until you have reached and set the +/- place:

Press  to set the flashing digit (or +/- sign) (3).

Press the enter key  to return to the decimal places (4).

Press the enter key  to complete the setting process (5).

Press one of the set keys ( or ) to save the values (6).

The instrument will display the function and parameter ID for the next parameter (7).

Example: Setting the switch-on value for switching output 1

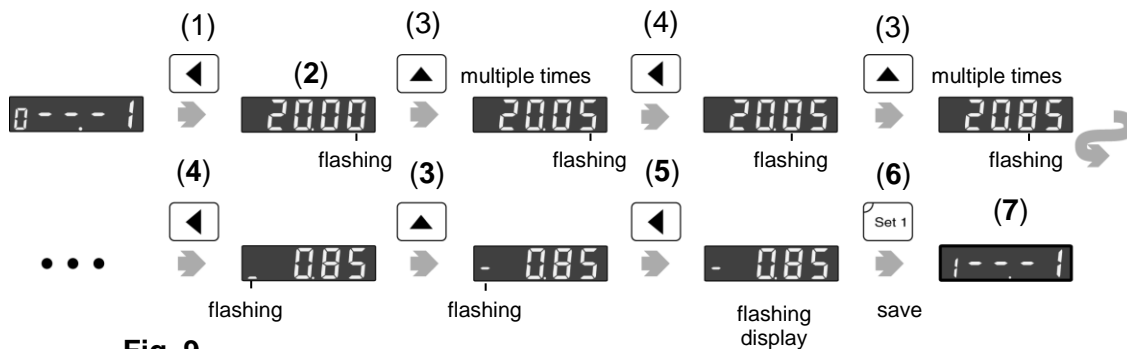

Fig. 9



The on and off values for each switch must have a min. difference of 2 digits to make sure that the switching output will work correctly. For an unstable signal a larger difference will give better results.

## 7 Troubleshooting

The instrument recognizes the following problems and responds by returning an error message:

<b>Error message</b>	<b>Problem</b>	<b>Cause</b>	<b>Corrective Action</b>
E003	overloaded pressure measurement capsule	pressure too high	send the instrument to the manufacturer for repair
E004	pressure measurement capsule is pressurized during zero-point calibration	pressure has not been disconnected defective pressure measurement capsule	reduce pressure send the instrument to the manufacturer for repair

**Table 6**

## 8 Technical data

<b>Measurement data</b>	
measurement ranges	$\pm 0 \dots 50 \text{ Pa}$ to $\pm 0 \dots 100 \text{ kPa}$ ; see rating plate
measurement principle	inductive
change in volume	0.1...0.3 mL
overload capacity	200x (for measurement ranges < 2.5 kPa)
	600 kPa (for measurement ranges > 2.5 kPa)
linearity	$\pm 1\%$
	$\pm 0.5\%$ (optional for measurement ranges > 250 Pa)
temperature-dependent drift in measured values	0.04% / K (+10° to +50°C)
temperature-dependent drift in the zero point	0.04% / K (+10° to +50°C)
zero-point drift over time	0.5 %/year
<b>Ambient conditions</b>	
medium	air, all non-aggressive gases
operating temperature	+10° to +50°C
storage temperature	-10° to +70°C
relative humidity	0 ... 80 %
EMC standards	EN 55011; EN 61000-4-3, EN 61000-4-6
conformity	 declaration of conformity available upon request
<b>Electrical data</b>	
power consumption	3 VA
supply voltage options	
standard	230 V-AC, +6 % / -15 % (50...60 Hz)
(optional)	24 V-AC, 115 V-AC, +6 % / -15 % (50...60 Hz)
(optional)	24 V-DC, +20 % / -15 %
analogue output	
standard	0..10 V (RL $\geq$ 2 k $\Omega$ )
(optional)	-5 ... 5 V; 0 ... 20 mA; 4 ... 20mA
time constant	1 sec. (standard), 2.5 and 10 s may be set by user
switching outputs	
standard	2 floating changeover relays; up to 230 V-Ac (50/60 Hz), 6 A w/ ohmic load
(optional)	2 bipolar NPN transistors; U <sub>CE</sub> < 50 V; I <sub>C</sub> < 200 mA, floating
time delay to analog output	none / 20 ms (standard)
electrical connections	12-pin terminal strip
connected cross-sections	0.5 ... 2 mm <sup>2</sup>

<b>Physical data</b>	
pressure port	2 pressure ports, $\varnothing = 6.5$ mm
housing material	glass reinforced Noryl
mounting orientation	horizontal

**Table 7**

## 9 Dimension drawings

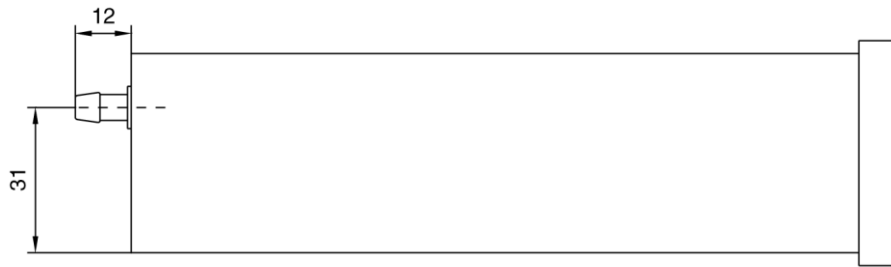

switch panel housing 48x96x163  
(DIN 43700)

Fig. 10 housing dimensions



## 10 Certificate of Conformity



Die Lösung liegt im Detail

**EG-Konformitätserklärung** im Sinne der  
EG- Richtlinie 2014/30/EU, EMV Richtlinie und  
2006/95/EG, Niederspannungsrichtlinie

**Certificate of Conformity** based on the  
European Standard 2014/30/EU, and 2006/95/EG

Der Hersteller  
The manufacturer

**halstrup-walcher GmbH  
Stegener Straße 10  
79199 Kirchzarten  
Deutschland**

erklärt, dass die Bauart des Produktes  
declares, that the construction of instrument type

**Differenzdruck-Messumformer Typ REG21  
Differential Pressure Transformer Type REG21**

entwickelt, konstruiert und gefertigt ist in Übereinstimmung mit den EG – Richtlinien  
is developed, designed and manufactured in accordance with the EC Directives.

EN 61000-6-2 : 2005  
EN 61000-6-4 : 2011  
EN 61010-1 : 2011

abgegeben durch / stated by:

Sura, Christian  
(Nachname, Vorname / Surname, first name)

Geschäftsführer, Managing Director  
(Stellung im Betrieb des Herstellers / Position )

Kirchzarten, 19.10.2016  
(Ort, Datum / City, Date)

  
(Rechtsgültige Unterschrift/ Signature)